



Price® Pump Co.

INSTALLATION, OPERATING AND MAINTENANCE MANUAL

AIR OPERATED DIAPHRAGM PUMPS
METALLIC, BOLTED, ALL ELASTOMERS

MODEL: 1.5 AOD-XXXX-B

PLEASE FILL IN FROM PUMP NAMEPLATE

Pump Model _____

Spec. No. _____

Serial No. _____

RETAIN MANUAL FOR REFERENCE



Price® Pump Company
21775 8th. Street East
Sonoma, CA 95476
Tel: 707-938-8441
Fax 707-938-0764
Email: sales@pricepump.com

Congratulations

You are now the owner of a Price® Pump Co. Air Operated Diaphragm Pump. This pump was carefully inspected and subjected to final performance tests before releasing for shipment. In order to achieve maximum performance and reliability, please follow the simple instructions in this manual.

RECOMMENDED PRECAUTIONS

1. For satisfactory operation and safety, maximum inlet air pressure must not exceed 125 psi (8.79kg/sq cm).
2. No modifications, additions or deletions should be made to the pump without prior approval of the factory.
3. Drain casing completely and flush with water before servicing a pump handling volatile or harmful liquids.

READ CAREFULLY THE CAUTION BELOW

The performance of your Price® Co. Air Operated Diaphragm Pump is based on clean, room temperature, water with suction conditions as shown on the performance curves. If used to pump other liquids, pump performance may differ from rated performance based on the different specific gravity, temperature, viscosity, etc. of the liquid being pumped. A standard pump, however, may not be safe for pumping all types of liquids, such as toxic, volatile or chemical liquids, or liquids under extreme temperatures or pressures.

Please consult Price® Pump catalogs as well as local codes and general references to determine the appropriate pump for your particular application. Since it is impossible for us to anticipate every application of a Price® pump, if you plan to use the pump for a non-water application, contact Price® Pump beforehand to determine whether such application may be proper and safe under the circumstances. Failure to do so could result in property damage or personal harm.

Visit our website for product information and technical support

www.pricepump.com

OPERATING INSTRUCTIONS

AIR OPERATED DIAPHRAGM PUMPS

BOLTED, ALL ELASTOMERS

INSTALLATION

Bolt pump to a mounting pad using appropriately sized diameter bolts. Rubber vibration insulators should be used between the pump mounting feet and mounting pad to reduce pump vibrations and stresses. In permanent installations the pump should not be directly attached to rigid piping, but instead should be connected through flexible hoses or equivalent on both the suction and discharge. This should be done to reduce pipe stresses and vibrations which are characteristic of the reciprocating nature of the pump. A surge suppressor may be required on the discharge line of the pump if further reduction in vibration or a reduction of pulsation in the discharge flow is desired.

If the pump is used in a submerged application a line or hose should be attached to the pump air exhaust to prevent liquid from entering the air valve when the pump is shutdown or operating at low discharge heads. CARE MUST BE EXERCISED WHEN SUBMERGING THE PUMP IN CORROSIVE PUMPING MEDIA.

Suction and discharge pipe size should be at least equal to the inlet pipe diameter or larger. Larger, if highly viscous liquid is to be pumped or long lengths of pipe are used. When using suction hoses use the non-collapsing reinforced type, since this pump is capable of producing high vacuum at the suction inlet.

SOLIDS-HANDLING CAPABILITY

Price® Pump Air Operated Diaphragm Pumps will pass the following spherical solid sizes:

Model	Particulate Size
1.5 AOD-XXXX-B	3/16" Dia. (4.7mm)
2.0 AOD-XXXX-B	3/8" Dia. (9.5mm)
3.0 AOD-XXXX-B	7/16" Dia. (11mm)

If the possibility exists that larger sized solids may be suspended or carried along by the pumping media, install a strainer on the suction line with smaller sized holes than the allowable solid size. This will prevent the larger solids from entering the pump and interfering with operation of the pump ball valves.

AIR SUPPLY

The inlet to the air valve is a female NPT. The air supply line should be sized accordingly so that there is no restriction less than inlet pipe size.

NOTE: Long air lines require larger diameters to minimize air system pressure loss to insure the required air pressure and flow rate at the pump air inlet. It is safe to use up to **125 psig (8.79 kg/sq cm)** for pumping requirements.

WARNING: DO NOT EXCEED 125 PSIG (8.79 KG/SQ CM) AIR SUPPLY PRESSURE AS COMPONENT DAMAGE OR PERSONAL INJURY MAY RESULT.

PUMP CONTROL

The pump operating conditions, flow (GPM) and discharge head (PSIG) can be controlled in the following manner

1. Throttling the pump discharge by means of a valve on the discharge line. When the pump discharge pressure equals the air supply pressure, the pump will stop. This will not harm the pump; however, do not exceed **125 psig (8.79 kg/sq cm)** air supply pressure. The pump may be in this mode indefinitely. By opening the discharge valve the pump will resume pumping.

2. The air pressure supply can be limited to the pump. Price® Pump recommends the installation of a Price® Pump air filter/pressure regulator for all AOD applications. A globe or gate valve can be used before the regulator for on or off control. Failure to use an air pressure regulator will cause the pump air inlet pressure and thus discharge pressure to climb to maximum air system pressure when the pump is stopped.

MINIMUM AIR SUPPLY PRESSURE

This air valve incorporates a stall-free design and will begin operating with air inlet pressures as low as **5 psig (.35 kg/sq cm)**.

OPERATING INSTRUCTIONS

OPERATING INSTRUCTIONS

The pump air valve is of an oilless design; that is, no lubrication is required or recommended. A clean, dry air supply should be provided for optimum air valve operation and life. In cold weather operation, or under conditions of high pump discharge pressure and relatively high humidity, air valve freezing may occur as a result of moisture in the compressed air being released. If this occurs, anti-freeze, of the ethylene glycol type, may be used in a measuring dispenser, such as an air line lubricator at the pump air inlet. The resulting mist will keep the air valve free of ice build-up.

1. In cases where there are several air-operated diaphragm pumps being used simultaneously and freezing of the air valve occurs frequently due to excessive moisture in the compressed air system, it may be advantageous to install a desiccant type compressed air dryer in the air system to purge the air supply of unwanted moisture.

For permanent installations, an air filter and water/oil separator should be used. This is always good practice, since it insures maximum life of the air valve moving parts and seals by keeping them clean of dirt and oil residue.

Excessive oil and water in the inlet air supply will cause a varnish-like substance to form on the self-lubricated valve spool. This will eventually lead to valve spool "sticking" and result in erratic spool operation. Should this occur, the spool and housing bore may be cleaned with a commercial safety solvent.

2. When starting the pump, make sure all valving on the suction and discharge lines are open. The pump will not prime with the valving closed. Pump cavitation will occur if the suction line is restricted with foreign matter, use a suction strainer with hole size less than allowable solid size for model in question.

3. When pumping highly viscous materials, it is advisable to check the pump flow rate vs. the pump stroke rate.

PUMP MODEL	AVG. GALS. PER STROKE*	
	Std. Elastomers	Teflon Elastomers
1.5 AOD-XXXX-B	.35 (1.3L)	.20 (.75L)
2.0 AOD-XXXX-B	.85 (3.2L)	.80 (3.0L)
3.0 AOD-XXXX-B	.8.7 (3.3L)	.82 (3.1L)

*Actual test data with flooded suction and specific gravity of 1.0.

One pump stroke is equal to one exhaust discharge. The pump should not pump faster than the material is capable of being drawn into the pump inlet. If this occurs, cavitation will occur and could damage to the pump.

4. To determine maximum pumping speed, increase air supply pressure while observing pump discharge increase. When discharge flow no longer increases, throttle back air until pump discharge flow starts to fall off. This point is the optimum pumping speed achievable under those controlled by either one of the two methods previously mentioned under the PUMP CONTROL section of this manual.

5. The pump air exhaust port should be kept free from blockage. The pump should never be operated submerged without installing a line to the exhaust port and directing the same above the liquid surface. An appropriately sized hose with a 1/2" male NPT connector may be piped up to the exhaust port and directed away. The exhaust line, if required, should be kept as short as possible or pump performance could be affected. If long lengths of exhaust line are necessary, increase the internal diameter of the exhaust line to minimize pressure drop and pump performance loss. If the exhaust sound level becomes too objectionable, use the air muffler provided.

NOTE: Installing an air exhaust muffler on a submerged pump will not prevent the liquid in which the pump is submerged, from entering the air valve.

CAUTION: If a diaphragm failure occurs, the pumping media may be blown out the exhaust port. This could be hazardous if the pumping media is toxic or aggressive. It is advisable to add a line to the exhaust port and direct it safely away when pumping toxic or aggressive media.

6. Drain pump and flush after use when pumping material which can pack, settle out of liquid suspension, or solidify in time. A packed pump can cause damage to the diaphragm clamping plates and pump shaft when started after a period of interrupted use. The pump may be inverted and drained through the discharge port and flushed through the suction port.

OPERATING TEMPERATURE

AOD-XXXX-B Wetted Parts

The pump should not be used to pump liquids above **180°F (82°C)**. For operating temperatures above **180°F (82°C)** consult factory.

TROUBLESHOOTING

TROUBLESHOOTING

1. Pump will run but will not pump.

- a. Check suction line for leaks.
- b. Tighten bolts or clamps on suction manifold of pumps.
- c. Material too viscous to pump at high rate of flow - slow down pump by reducing air supply pressure to pump or use larger diameter suction line.
- d. Suction manifold & pump chambers misaligned - disassemble & realign.
- e. Suction or discharge balls jammed open with foreign object - disassemble pump and remove foreign object.

NOTE: Optimum priming speed for these pumps is obtained when air inlet pressure is maintained between 15-20 psi, (1.0-1.4 kg/cm²) with open pump discharge.

2. Air bubbles in pump discharge line

- a. Check suction line and manifold bolts or clamps for leaks.
- b. Cracked or ruptured diaphragm.

3. Intermittent pump operation and/or ice blowing from exhaust port.

- a. Remove obstruction from suction line.
- b. Valve freeze-up - install de-icing device on air inlet line or suitable air dryer in compressed air line.
- c. Sticky air valve - remove main spool & clean with safety solvent.

4. Pump stops pumping.

- a. Increase air supply pressure but **DO NOT exceed 125 psig (8.79 kg/cm²)** under any circumstances and check for obstruction in suction or discharge line.
- b. Spool sticking - remove main spool & clean with safety solvent - install suitable filter on air inlet if dirt or contaminants persist.
- c. Air valve ice-up - excess moisture on the muffler is an indication that significant water is present in the air supply. Depending on the degree of severity, an in line water separator or air dryer is recommended.

5. Severe pump vibration with intermittent flow.

- a. Ruptured diaphragm - disassemble pump, replace diaphragm and clean air valve if necessary.
- b. Mechanical failure - disassemble pump and inspect for bent shaft, ruptured diaphragm, other part failure.

6. Pumping media leaking from exhaust port.

- a. Ruptured diaphragm - disassemble pump, replace diaphragm - clean air valve if necessary.

7. Varying pump discharge per stroke.

- a. Remove suction manifold and check for obstructions.
- b. Worn or leaky ball valves & seats - disassemble pump and replace worn parts.
- c. Check to verify bolts are fastened tightly and re-torque if necessary.

8. Slowing of pumping action

- a. Clogged air exhaust muffler - clean or replace
- b. Ice buildup in air valve - install de-icing device on air inlet line.

REPAIR AND MAINTENANCE

PUMP DISASSEMBLY INSTRUCTIONS

AOD-XXXX-B (Bolted Design) ALL ELASTOMERS

Prior to disassembly of any AOD pump follow the "caution" below.

CAUTION; Do not attempt to perform any maintenance or repair on the air operated diaphragm pumps until the compressed air line to the pump and pump discharge line has been shut off, bled down, and disconnected. In addition, when pumps are being used to pump toxic or aggressive media the pumps should be flushed clean prior to disassembly.

1. Pump should be disassembled in the normal upright position. Remove the discharge manifold by removing the cap screws and lock washers.
2. Remove ball valves, ball valve seats and o-rings (Teflon only) from Discharge Manifold.
3. Turn the unit upside down so that the suction manifold is facing up. Remove the suction manifold by removing the cap screws and lock washers.
4. Remove ball valves, ball valve seats and o-rings (Teflon only) from both pump chambers.
5. Check all ball valves, and ball valve seats for excessive wear or deep gouges. Replace if necessary. Excessively worn parts will adversely affect pump performance.
6. Turn unit on its side so that it is resting on one of the pump chambers. Remove the cap screws, lock washers and hex nuts fastening the other pump chamber to its air valve half.

Remove pump chamber. Depress diaphragm assembly into the air valve half by gently pushing on the outer diaphragm plate.

7. Turn the unit over so that it is resting on the air valve half and the other pump chamber is facing up. Remove pump chamber per the previous instructions from step #6.

8. Place the hex head of one of the outer diaphragm plates (or ESNA nut) in a table vise and remove the opposing outer diaphragm plate (or EASA nut) using a socket, box wrench, or adjustable wrench. If a vise is not available two wrenches can be used. Remove the diaphragm, inner diaphragm plate, and bumper.

9. Remove pump shaft and remaining diaphragm assembly (still attached) from pump by sliding through the sleeve bearings. Place free end of shaft in a soft metal jaws vise (or place two blocks of wood between the vise jaws to protect the shaft) and remove the outer diaphragm plate and the remaining parts.

10. Check both diaphragms and rubber bumpers for wear. Replace if necessary. Excessively worn parts will adversely affect pump performance.

11. Check shaft sleeve bearings and inner clamp plate for wear or mechanical damage. Replace any worn parts.

12. Refer to air valve disassembly instructions in this manual.

REPAIR AND MAINTENANCE

RE-ASSEMBLY INSTRUCTIONS FOR

AOD-XXXX-B (Bolted Design)

ALL ELASTOMERS EXCEPT TEFLON

1. Gently insert the pump shaft into the sleeve bearing of the air valve housing, until the last radiused edge of the pump shaft just passes through the sleeve bearing seal. Push the pump shaft back through the sleeve bearing seal from the opposite end and center the pump shaft in the air valve assembly. The pump shaft should move freely without binding.

2. Place the air valve assembly on a clean flat surface. Slide a new rubber bumper onto shaft. Place the inner diaphragm plate onto the shaft with the O-ring groove facing upward. Place diaphragm with the words "Fluid Side" facing upward, away from the air-valve assembly. Apply a few drops of Blue-Loctite #242 (or equivalent) to the pump shaft threads. Thread on the outer diaphragm plate (or ESNA Nut with diaphragm plate) onto pump shaft. "Hand" tighten the outer diaphragm plate, but do not torque down completely until later in the assembly process.

3. Turn the air valve assembly over so that the threaded end of the shaft is pointing upward. Slide a new rubber bumper onto shaft. Place the inner diaphragm plate onto the shaft with the O-ring groove facing upward. Place diaphragm with the words "Fluid Side" facing upward, away from the air-valve assembly. Apply a few drops of Blue-Loctite #242 (or equivalent) to the pump shaft threads. Thread on the outer diaphragm plate (or ESNA Nut with diaphragm plate) onto pump shaft. "Hand" tighten the outer diaphragm plate, but do not torque down completely until later in the assembly process.

4. Place the hex head of one of the outer plates (or ESNA nut) in a table vise and tighten the opposing outer diaphragm plate using a socket or box wrench. Torque the assembly to **35 ft. lbs. (47n-m)**. Be certain both outer diaphragm plates are torqued to **35 ft. lbs. (47n-m)**.

5. Depress one of the diaphragm assemblies completely into one of the air valve halves. Set this side flat onto a clean flat surface so that the other diaphragm is facing up.

6. Carefully align the outer bead of the diaphragm with the groove on the air valve half. Place the pump chamber over the diaphragm so that the bead on the diaphragm is aligned with the groove on the pump chamber. The pump chamber should be oriented so the "PP" logo is upright. The main spool housing should be at the top, adjacent to the discharge flanges. Assemble the pump chamber to the air valve half (using twelve cap screws, lock washers and hex nuts).

Torque each cap screw, using a "Cross-Sequence" to **15 ft. lbs. (20n-m)**.

7. Turn the unit over so that it is resting on the pump chamber previously fastened. Repeat step #6 for the other side of the unit.

Note: Place air valve and pump chamber assembly, upside down, on a clean flat surface. Make sure the manifold flanges are parallel to each other. This can be confirmed by placing the suction manifold on top of the chambers and checking the mating surfaces.

8. With the unit upside down so that it is resting on the discharge flange of the pump chamber and the suction flange is facing up. Place a ball valve seat, & ball valve into each flange counter bore of the suction manifold.

Note: Be sure the raised O-ring contour, on the ball valve seat, faces **inward** when installed into the flange counter bore, of the suction manifold and pump chambers.

9. Fasten the suction manifold to each pump chamber using eight lock washers and cap screws. Torque each cap screw to **25 ft. lbs. (34n-m)**.

10. Turn the unit right-side up so that it is standing on its feet. Place a ball valve seat & ball valve into the pump chamber. Check to make sure the surface of the "O"-ring is above the surface of the pump chamber.

REPAIR AND MAINTENANCE

11. Fasten the discharge manifold to each pump chamber using eight lock washers and cap screws. Torque each cap screw to **25 ft. lbs. (34n-m)**. Note that the suction and discharge manifolds can be oriented to fit the installation requirements.

RE-ASSEMBLY INSTRUCTIONS FOR

AOD-XXXX-B (Bolted Design) TEFLON ELASTOMERS

1. Gently insert the pump shaft into the sleeve bearing of the air valve housing, until the last radiused edge of the pump shaft just passes through the sleeve bearing seal. Push the pump shaft back through the sleeve bearing seal from the opposite end and center the pump shaft in the air valve assembly. The pump shaft should move freely without binding.

2. Place the air valve assembly on a clean flat surface. Slide a new rubber bumper onto shaft, inner diaphragm plate, backup diaphragm "Fluid Side Out.", Teflon diaphragm, diaphragm guard, and outer diaphragm plate (or ESNA Nut with diaphragm plate) to pump shaft. Apply a few drops of Blue Loctite #242 (or equivalent) to pump shaft threads. Tighten outer clamping plate but do not torque down completely until later in the reassembly.

Depress one of the diaphragm assemblies completely into one of the air valve halves. Set this side flat onto a clean flat surface so that the other diaphragm is facing up.

3. Carefully align the Gortex tape along the outer bead of the diaphragm. Now align the taped outer bead of the diaphragm with the groove on the air valve half. Place the pump chamber over the diaphragm so that the bead on the diaphragm is aligned with the groove on the pump chamber.

Assemble the pump chamber to the air valve half using twelve cap screws lock washers and hex nuts.

Torque each cap screw, using a "Cross-Sequence" to **15 ft. lbs. (20n-m)**.

4. Turn the unit over so that it is resting on the pump chamber previously fastened. Repeat step #'s 3 and 4 for the other side of the unit.

5. Turn unit upside down so that it is resting on the discharge flange of the pump chamber and the suction flange is facing up. Insert ball valve, "O"-ring, ball valve seat and "O"-ring into each suction port of the pump chamber. Check to make sure the surface of the "O"-ring is above the surface of the pump chamber flange.

6. Fasten the suction manifold to each pump chamber using eight lock washers and cap screws. Torque each cap screw to **15 ft. lbs. (20n-m)**.

7. Turn the unit right-side up so that it is standing on its feet. Place a ball valve, "O"-ring, ball valve seat, and "O"-ring into each discharge manifold flange. Check to make sure the surface of the "O"-ring is above the surface of the manifold flange.

8. Fasten the discharge manifold to each pump chamber using eight lock washers and cap screws.

Torque each cap screw to **15 ft. lbs. (20n-m)**. Note that the suction and discharge manifolds can be oriented to fit the installation requirements.

REPAIR AND MAINTENANCE

AOD AIR VALVE DISASSEMBLY INSTRUCTIONS

POLYPROPYLENE, PVDF & AOD-XXXX CLAMPED & BOLTED, ALL ELASTOMERS

REMOVAL OF AIR CHAMBERS

1. Remove the five hex nuts, lock washers, special flat washers and flat head socket screws which retain one of the air chambers to the air valve housing. Repeat this step for the opposite air chamber.
2. Loosen the connection between the long flathead screw and short flat head screw at coupling nut by turning both and counter clockwise using two Allen wrenches. Loosen lock-nut from coupling nut, and remove both from long flat head screw.
3. Set aside gaskets and, if used, air chamber clamping rings. Plastic pumps are bolted while metallic pumps can either use clamping rings or be bolted. Remove seals from both air chambers. Replace these items during reassembly.

AIR VALVE BODY DISASSEMBLY INSTRUCTIONS

1. Remove spool housing end caps, gaskets and cap screws from spool housing.
2. Remove main spool and examine spool, piston rings and ring expanders for wear. Replace piston ring set & spool if deeply scratched, chipped or worn. New spools will be interchangeable with old. If main spool bore in spool housing has become corroded, excessively pitted, or deeply scratched replace spool housing.
3. Remove muffler from air valve housing and check inside for dirt and debris. If muffler is clogged it will affect pump performance. Replace if necessary.
4. Remove spool housing and gasket by removing the four socket head cap screws and lock washers. Check gasket for any degradation and replace if required.
5. Inspect 'OilLte' bronze sleeve bushings in valve housing. Replace as necessary.
6. Remove the pilot spool from the air valve by pulling out at one end. Remove the piston ring assemblies from

each end of the pilot spool. Examine for wear and replace as necessary.

7. The air valve assembly is now completely disassembled.

AIR VALVE BODY REASSEMBLY INSTRUCTIONS

CAUTION: Care must be taken at this stage of reassembly to ensure cleanliness. A dirty valve will stick and will not work properly. Keep area free of dirt, oil, and metal chips.

1. Clean all metal parts with good grade safety solvent prior to reassembly.
2. Press shaft bushings into air valve housing, making sure they are properly aligned with the bore in the valve housing. Press bushings in to a height of **0.165"** above the flush position.
3. Install new piston ring assemblies on pilot spool. Push pilot spool with piston rings into bore of air valve. Take care to position splits in piston rings to 3 o'clock or 9 o'clock position in bore.
4. Inspect spool for scratches, scoring, chips, and wear. If severe grooving or marking is evident, replace spool. To ensure maximum performance the spool should not be excessively worn, although the pump will still run satisfactorily.
5. Insert piston ring seals and expander rings prior to reassembly. Replace with new if required.

NOTE: Upon reassembly of piston ring seals and expander rings the opening in the expander ring and the split in the piston ring should be assembled 180° apart. Also, upon reassembling the spool to the spool housing bore, rotate piston ring seals in their grooves until the split in the seal is at the valve housing 3 or 9 o'clock position. This prevents the split from covering valve housing ports during reassembly. This also eliminates the tendency to hang up on a port. Do not install main spool in a centered position or pump may not start.

6. Install spool housing cap gaskets with existing end caps and 1/4" - 20 Allen head screws at both ends of spool housing.

REPAIR AND MAINTENANCE

7. Position new gasket and spool housing assembly onto valve housing and secure with four Allen head screws, and lock washers. Torque screws to **7 ft-lbs. (9.5 n-m)**.

8. Check muffler to make sure that it is clean and free of debris. If it cannot be cleaned, replace with new. Install muffler in air valve housing. Do not over-tighten. One quarter turn past hand tight should be sufficient.

AIR CHAMBER REASSEMBLY TO AIR VALVE BODY

1. Install new seals in both air chambers. Important! The lips of seal must face away from the air valve housing and the lips of seal must face inward towards the center of the air valve housing.

2. Align gasket with air valve housing and attach air chamber using five flathead screws, special flat washers, lock washers and hex nuts.

NOTE: For any model which uses air chamber clamp rings make certain to place the clamp rings in position before attaching air chambers to the air valve body. The beveled edge of the clamp ring should face towards the air chamber.

3. Thread long flat head screw through the appropriate hole in the opposite air chamber and gasket, which lines up with the hole left blank in step 2 when this air chamber was installed. Thread locknut and coupling nut onto long flathead screw. Lock coupling nut in place with locknut.

4. Install second air chamber with gasket and long flathead screw with locknut and coupling nut onto air valve. Attach air chamber to air valve using five flathead screws (9), special flat washers, lock washers and hex nuts.

5. Install short, flat head screw in blank hole in first air chamber, then engage coupling nut. Tighten flat head screws and using two Allen wrenches. Torque all air chamber to air valve hardware to **7 ft-lbs. (9.5 n-m)**.

6. The air valve assembly is now completely refurbished and ready for further pump assembly.

THIS PAGE INTENTIONALLY LEFT BLANK



1 1/2" AOD Bolted Stainless Steel Parts List

(Teflon Elastomers)

PRICE PUMP CO.

AOD1.5BSS-Tplst.doc

Key #	Description	Qty	Part #	Material
1	Chamber, Pump	2	46-130-10	Stainless Steel
4	Plate, Diaphragm (Outer)	2	44-904-10	Stainless Steel
6	Diaphragm	2	44-150-50	Teflon
7	Plate, Diaphragm (Inner)	2	46-852-00	Stainless Steel
8	Bumper	2	44-151-00	Polyurethane
9	Cap Screw	10	51-750-00	Stainless Steel
12 +	Seal	2	44-431-00	Molythane
14 +	Seal	2	44-432-00	Molythane
15 +	Gasket, Air Valve / Chamber	2	46-564-00	Rubber
16	Shaft, Pump	1	46-478-00	Steel - Nitrided
17	"D" Flat Washer	10	47-370-00	Stainless Steel
19	Cap Screw, Hex Head	32	60-024-00	Stainless Steel
20	Lock Washer	32	60-055-00	Stainless Steel
23	Manifold, Discharge	1	46-131-10	Stainless Steel
24	Manifold, Suction	1	46-132-10	Stainless Steel
28	Seat, ball Valve	4	46-102-00	Stainless Steel
29	Ball, Valve	4	44-144-50	Teflon
32	Hex Nut	16	60-061-00	Stainless Steel
35	Cap Screw, Socket Head	8	51-640-00	Steel - Zinc Plated
36	Cap, Spool, Air Valve	2	45-743-00	Nylon, Glass Filled
37 +	Gasket, Cap	2	45-728-00	Polyurethane 85 +/- Duro
39 +	Spool, Air Valve	1	47-196-00	Phenolic
43 +	Sleeve, Bushing	2	44-186-00	Bronze
44 +	Muffler	1	44-284-66	Polypropylene
45 +	Piston Ring, Air Valve	2	44-427-00	Phenolic
46 +	Ring, Expander, Air Valve	2	44-537-00	Stainless Steel
47	O-ring	8	46-103-00	Teflon
48	Diaphragm, Backup	2	46-197-00	Buna
50	Diaguard	2	46-105-00	Teflon
51	Gortex Tape	2	60-001-00	Teflon
61	Lock Washer	14	60-053-00	Stainless Steel
62	Hex Nut	11	51-743-00	Stainless - Zinc Plated
65 +	Gasket, Air Valve / Spool	1	47-348-00	Fiber
66	Flat SOC Cap	1	51-751-00	Oxide Coated Steel
67	O-ring	12	47-351-00	Buna
68	Housing, Spool	1	46-496-10	Aluminum, Anodized
78	Housing, Air Valve	1	46-495-10	Cyglass
82 +	Pilot Spool, Air Valve	1	47-341-00	Stainless Steel
83 +	Spool Ring, Air Valve	2	47-463-00	Buna / Phenolic
85	Coupling Nut, Hex	1	46-533-00	Steel - Zinc Plated
86	Chamber, Air	2	47-344-04	Aluminum
89	Cap Screw	2	60-037-00	Stainless Steel
91	Cap Screw	1	60-036-00	Stainless Steel
95	Cap Screw, Socket Head	4	51-749-00	Stainless Steel
	Air Valve Rebuild Kit			
	-Includes all parts with +	1	47-664-00	
	Elastomer Kit	1	46-200-55	



PRICE PUMP CO.

1-1/2" Stainless Steel Bolted AOD
Teflon Elastomers

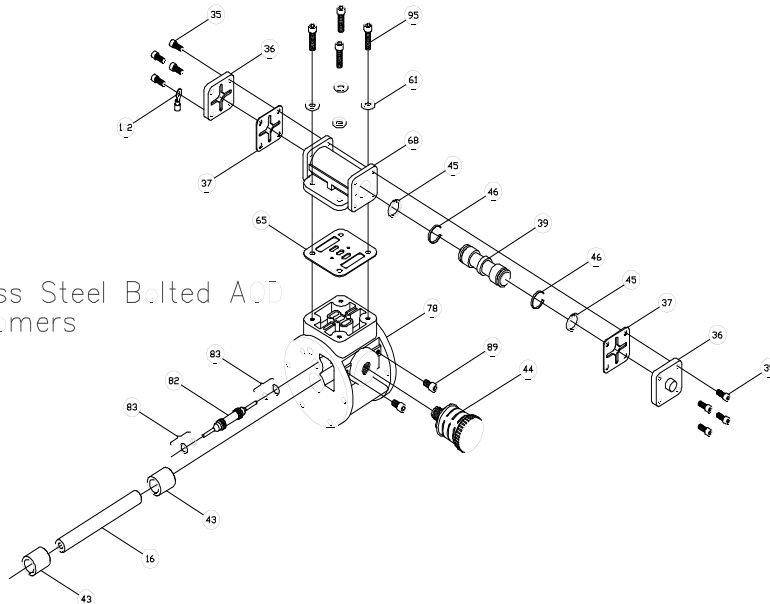

44-382-11/WG rev. C

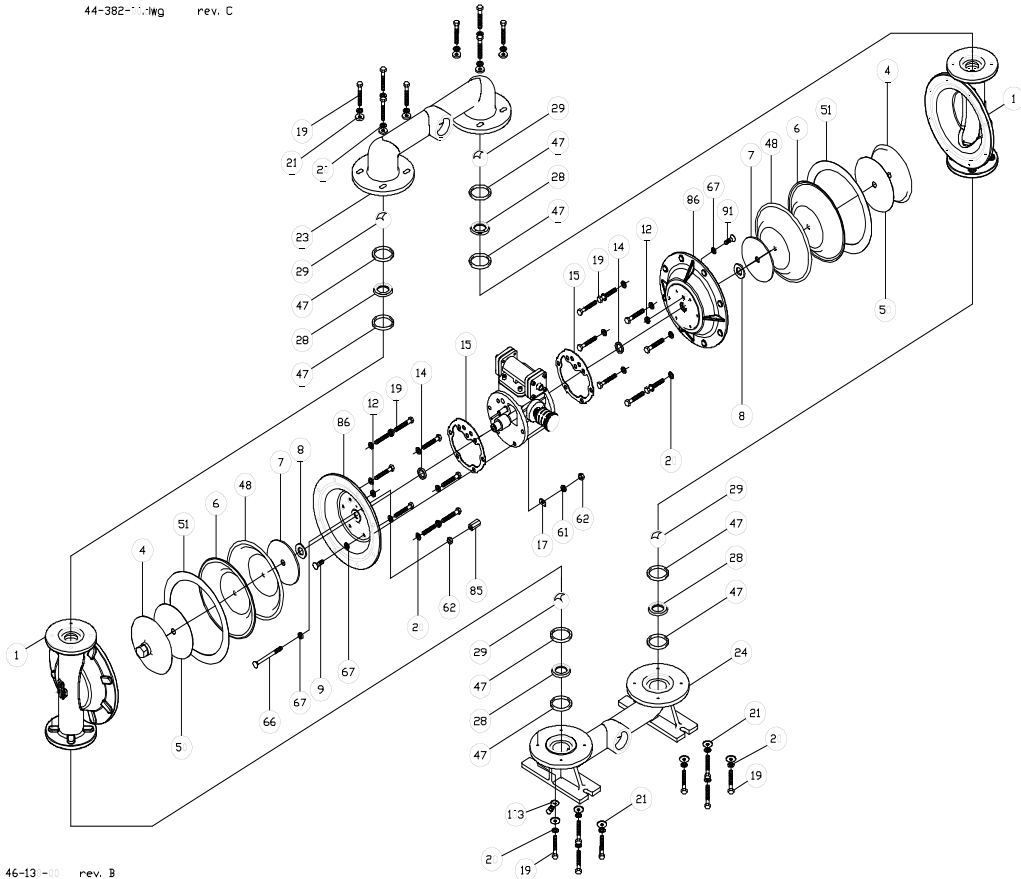

46-13-00 rev. B

Price[®] Pump Co.

21775 Eighth Street East * Sonoma, CA 95476 * Phone (707) 938-8441 * Fax (707) 938-0764



1 1/2" AOD Bolted Aluminum Parts List

(Teflon Elastomers)

PRICE PUMP CO.

AOD1.5BAL-Tplist.doc

Key #	Description	Qty	Part #	Material
1	Chamber, Pump	2	47-122-56	Aluminum
2	Lock Nut	2	51-660-00	Steel - Zinc Plated
4	Plate, Diaphragm (Outer)	2	44-148-04	Aluminum
6	Diaphragm	2	44-150-50	Teflon
7	Plate, Diaphragm (Inner)	2	46-852-00	Stainless Steel
8	Bumper	2	44-151-00	Polyurethane
9	Cap Screw	10	51-750-00	Stainless Steel
12 +	Seal	2	44-431-00	Molythane
14 +	Seal	2	44-432-00	Molythane
15 +	Gasket, Air Valve / Chamber	2	46-564-00	Rubber
16	Shaft, Pump	1	46-478-00	Steel - Nitrided
17	"D" Flat Washer	10	47-370-00	Stainless Steel
19	Cap Screw, Hex Head	32	60-024-00	Stainless Steel
20	Lock Washer	32	60-055-00	Stainless Steel
21	Washer	32	52-128-43	Stainless Steel
23	Manifold, Discharge	1	47-120-56	Aluminum
24	Manifold, Suction	1	47-121-56	Aluminum
28	Seat, ball Valve	4	46-102-10	Aluminum
29	Ball, Valve	4	44-144-50	Teflon
35	Cap Screw, Socket Head	8	51-640-00	Steel - Zinc Plated
36	Cap, Spool, Air Valve	2	45-743-00	Nylon, Glass Filled
37 +	Gasket, Cap	2	45-728-00	Polyurethane 85 +/- Duro
39 +	Spool, Air Valve	1	47-196-00	Phenolic
43 +	Sleeve, Bushing	2	44-186-00	Bronze
44 +	Muffler	1	44-284-66	Polypropylene
45 +	Piston Ring, Air Valve	2	44-427-00	Phenolic
46 +	Ring, Expander, Air Valve	2	44-537-00	Stainless Steel
47	O-ring	8	46-103-00	Teflon
48	Diaphragm, Backup	2	46-197-00	Buna
50	Diaguard	2	46-105-00	Teflon
51	Gortex Tape	2	60-001-00	Teflon
61	Lock Washer	14	60-053-00	Stainless Steel
62	Hex Nut	11	51-743-00	Stainless - Zinc Plated
65 +	Gasket, Air Valve / Spool	1	47-348-00	Fiber
66	Flat SOC Cap	1	51-751-00	Oxide Coated Steel
67	O-ring	12	47-351-00	Buna
68	Housing, Spool	1	46-496-10	Aluminum, Anodized
78	Housing, Air Valve	1	46-495-10	Cyglass
82 +	Pilot Spool, Air Valve	1	47-341-00	Stainless Steel
83 +	Spool Ring, Air Valve	2	47-463-00	Buna / Phenolic
85	Coupling Nut, Hex	1	46-533-00	Steel - Zinc Plated
86	Chamber, Air	2	47-344-04	Aluminum
89	Cap Screw	2	60-037-00	Stainless Steel
91	Cap Screw	1	60-036-00	Stainless Steel
95	Cap Screw, Socket Head	4	51-749-00	Stainless Steel
	Air Valve Rebuild Kit			
	-Includes all parts with +	1	47-664-00	
	Elastomer Kit	1	46-200-55	



PRICE PUMP CO.

1-1/2" Aluminum Bolted AOD
Teflon Elastomers

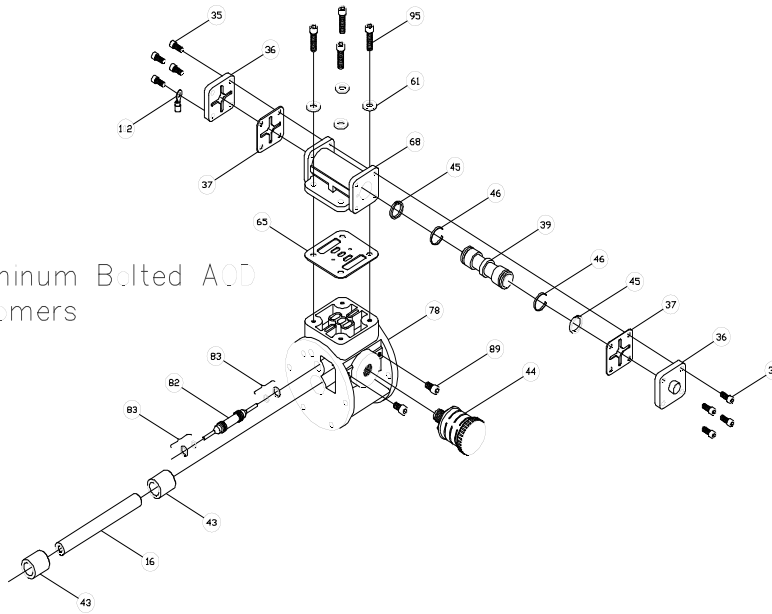

44-382-00.lwg rev. C

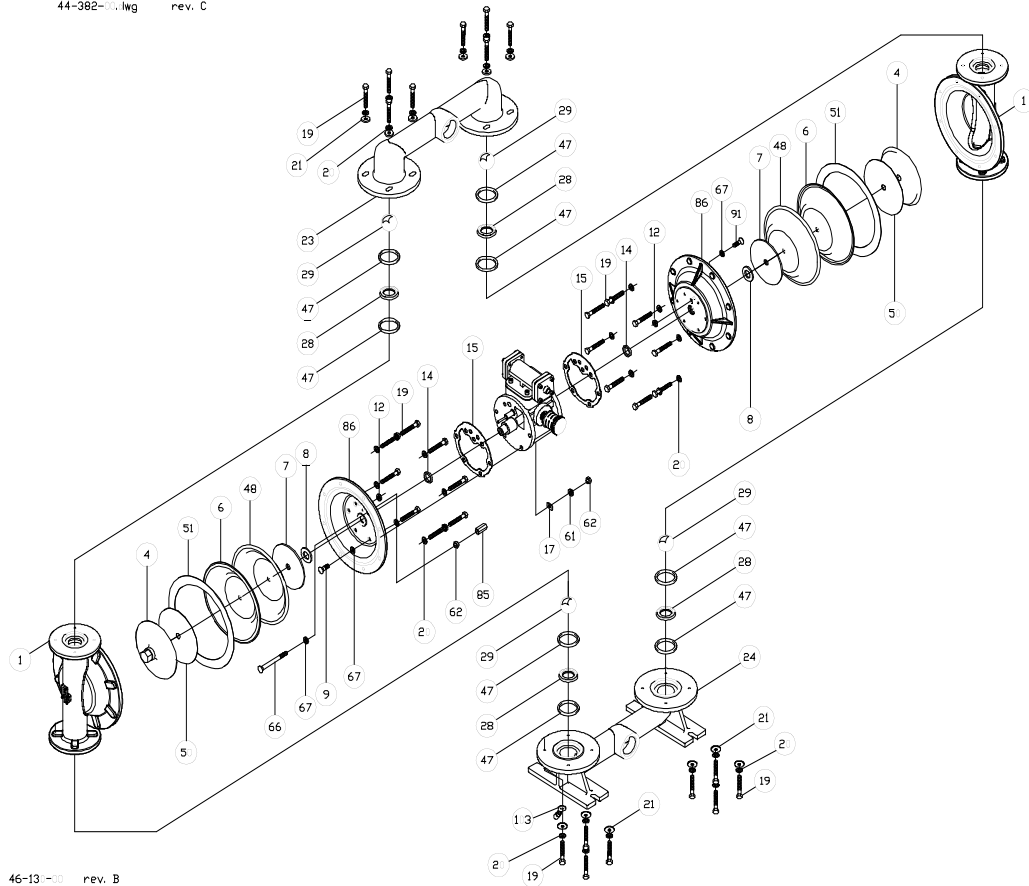

46-13-00 rev. B

Price Pump Co.

21775 Eighth Street East * Sonoma, CA 95476 * Phone (707) 938-8441 * Fax (707) 938-0764



1 1/2" AOD Bolted Stainless Steel Parts List

(All Elastomers Except Teflon)

PRICE PUMP CO.

AOD1.5BSSplist.doc

Key #	Description	Qty	Part #	Material
1	Chamber, Pump	2	46-130-10	Stainless Steel
4	Plate, Diaphragm (Outer)	2	44-904-10	Stainless Steel
6	Diaphragm	2	44-150-**	Customers Preference
7	Plate, Diaphragm (Inner)	2	46-852-00	Stainless Steel
8	Bumper	2	44-151-00	Polyurethane
9	Cap Screw	10	51-750-00	Stainless Steel
12 +	Seal	2	44-431-00	Molythane
14 +	Seal	2	44-432-00	Molythane
15 +	Gasket, Air Valve / Chamber	2	46-564-00	Polyurethane
16	Shaft, Pump	1	44-152-00	Steel - Nitrided
17	"D" Flat Washer	10	47-370-00	Stainless Steel
19	Cap Screw, Hex Head	32	60-024-00	Stainless Steel
20	Lockwasher	32	60-055-00	Stainless Steel
23	Manifold, Discharge	1	46-131-10	Stainless Steel
24	Manifold, Suction	1	46-132-10	Stainless Steel
28	Seat, ball Valve	4	44-145-**	Customer Preference
29	Ball, Valve	4	44-144-**	Customer Preference
32	Hex Nut	16	60-061-00	Stainless Steel
35	Cap Screw, Socket Head	8	51-640-00	Steel - Zinc Plated
36	Cap, Spool, Air Valve	2	45-743-00	Nylon, Glass Filled
37 +	Gasket, Cap	2	45-728-00	Polyurethane
39 +	Spool, Air Valve	1	47-196-00	Phenolic
43 +	Sleeve, Bushing	2	44-186-00	Bronze
44 +	Muffler	1	44-284-66	Polypropylene
45 +	Piston Ring, Air Valve	2	44-427-00	Phenolic
46 +	Ring, Expander, Air Valve	2	44-537-00	Stainless Steel
61	Lock Washer	14	60-053-00	Stainless Steel
62	Hex Nut	11	51-743-00	Stainless - Zinc Plated
65 +	Gasket, Air Valve / Spool	1	47-348-00	Fiber
66	Carriage Bolt	1	51-751-00	Oxide Coated Steel
67	O-ring	12	47-351-00	Buna
68	Housing, Spool	1	46-496-10	Aluminum, Anodized
78	Housing, Air Valve	1	46-495-10	Cyglass
82 +	Pilot Spool	1	47-341-00	Stainless Steel
83 +	Spool Ring Assembly, Air Valve	2	47-463-00	Neoprin / Phenolic
85	Coupling Nut, Hex	1	46-533-00	Steel - Zinc Plated
86	Chamber, Air	2	47-344-04	Aluminum
89	Cap Screw, Socket Head	2	60-037-00	Stainless Steel
91	Cap Screw	1	60-036-00	Stainless Steel
95	Cap Screw, Socket Head	4	51-749-00	Stainless Steel
	Air Valve Rebuild Kit			
	-Includes all parts with +	1	47-664-00	
	Elastomer Kit	1	44-808-**	

** Elastomers:
 00 - Neoprene
 10 - Buna-N
 20 - Viton
 30 - Nordel
 60 - Santoprene



PRICE PUMP CO.

1-1/2" Stainless Steel Bolted AOD
All Elastomers (Except Teflon)

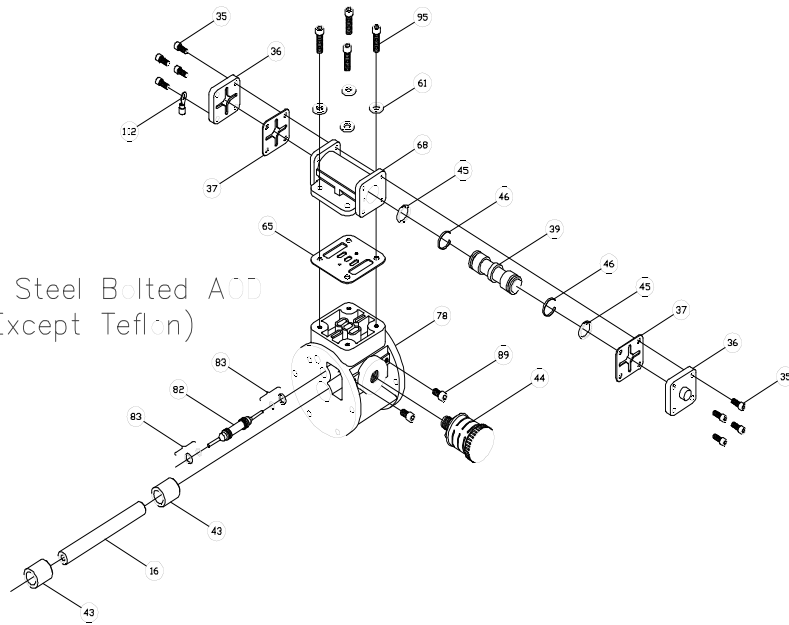

44-382-001kg rev. C

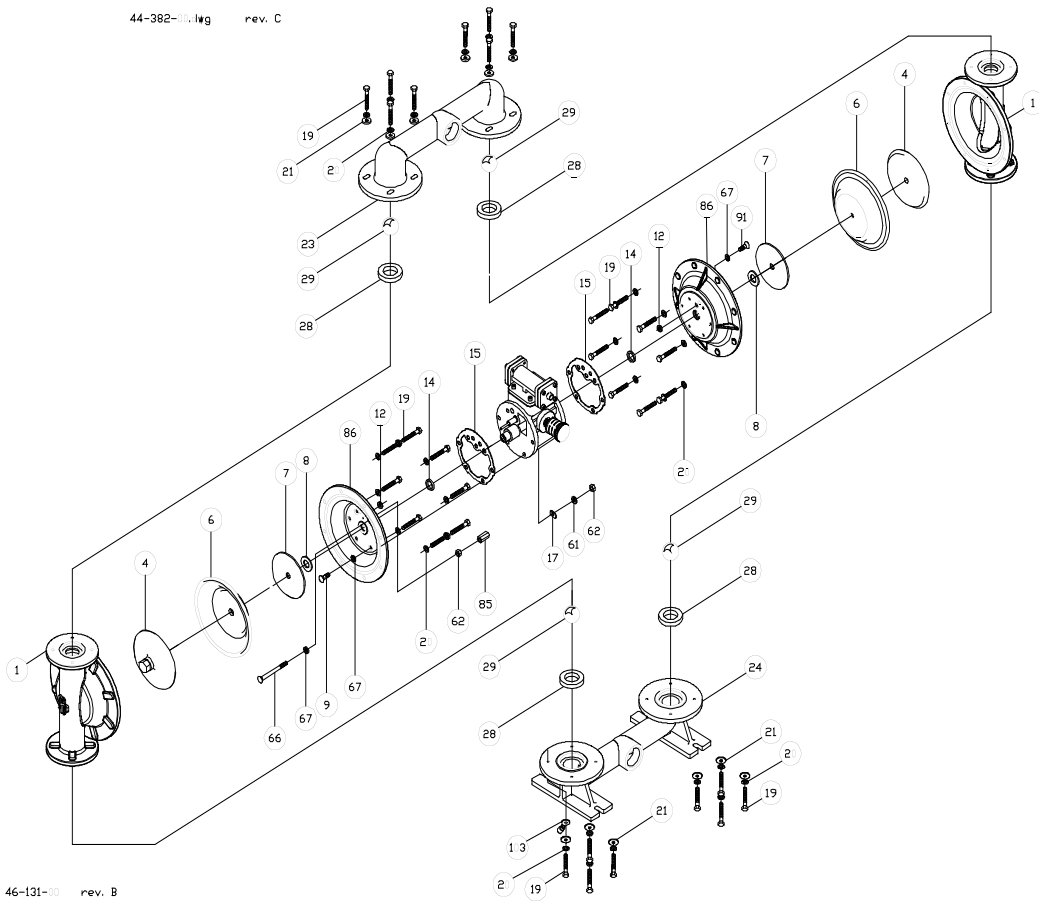

46-131-00 rev. B

Price Pump Co.

21775 Eighth Street East * Sonoma, CA 95476 * Phone (707) 938-8441 * Fax (707) 938-0764



1 1/2" AOD Bolted Aluminum Parts List

(All Elastomers Except Teflon)

PRICE PUMP CO.

AOD1.5BALplist.doc

Key #	Description	Qty	Part #	Material
1	Chamber, Pump	2	47-122-56	Aluminum
2	Lock Nut	2	51-660-00	Steel - Zinc Plated
4	Plate, Diaphragm (Outer)	2	44-148-04	Aluminum
6	Diaphragm	2	44-150-**	Customers Preference
7	Plate, Diaphragm (Inner)	2	46-852-00	Stainless Steel
8	Bumper	2	44-151-00	Polyurethane
9	Cap Screw	10	51-750-00	Stainless Steel
12 +	Seal	2	44-431-00	Molythane
14 +	Seal	2	44-432-00	Molythane
15 +	Gasket, Air Valve / Chamber	2	46-564-00	Polyurethane
16	Shaft, Pump	1	44-152-00	Steel - Nitrided
17	"D" Flat Washer	10	47-370-00	Stainless Steel
19	Cap Screw, Hex Head	32	60-024-00	Stainless Steel
20	Lockwasher	32	60-055-00	Stainless Steel
21	Washer	32	52-128-43	Stainless Steel
23	Manifold, Discharge	1	47-120-56	Aluminum
24	Manifold, Suction	1	47-121-56	Aluminum
28	Seat, ball Valve	4	44-145-**	Customer Preference
29	Ball, Valve	4	44-144-**	Customer Preference
35	Cap Screw, Socket Head	8	51-640-00	Steel - Zinc Plated
36	Cap, Spool, Air Valve	2	45-743-00	Nylon, Glass Filled
37 +	Gasket, Cap	2	45-728-00	Polyurethane
39 +	Spool, Air Valve	1	47-196-00	Phenolic
43 +	Sleeve, Bushing	2	44-186-00	Bronze
44 +	Muffler	1	44-284-66	Polypropylene
45 +	Piston Ring, Air Valve	2	44-427-00	Phenolic
46 +	Ring, Expander, Air Valve	2	44-537-00	Stainless Steel
61	Lock Washer	14	60-053-00	Stainless Steel
62	Hex Nut	11	51-743-00	Stainless - Zinc Plated
65 +	Gasket, Air Valve / Spool	1	47-348-00	Fiber
66	Carriage Bolt	1	51-751-00	Oxide Coated Steel
67	O-ring	12	47-351-00	Buna
68	Housing, Spool	1	46-496-10	Aluminum, Anodized
78	Housing, Air Valve	1	46-495-10	Cyglass
82 +	Pilot Spool	1	47-341-00	Stainless Steel
83 +	Spool Ring Assembly, Air Valve	2	47-463-00	Neoprin / Phenolic
85	Coupling Nut, Hex	1	46-533-00	Steel - Zinc Plated
86	Chamber, Air	2	47-344-04	Aluminum
89	Cap Screw, Socket Head	2	60-037-00	Stainless Steel
91	Cap Screw	1	60-036-00	Stainless Steel
95	Cap Screw, Socket Head	4	51-749-00	Stainless Steel
	Air Valve Rebuild Kit			
	-Includes all parts with +	1	47-664-00	
	Elastomer Kit	1	44-808-**	

** Elastomers:
 00 - Neoprene
 10 - Buna-N
 20 - Viton
 30 - Nordel
 60 - Santoprene



PRICE PUMP CO.

1.5AODB-AL.dwg

1-1/2" Aluminum Bolted AOD
All Elastomers (Except Teflon)

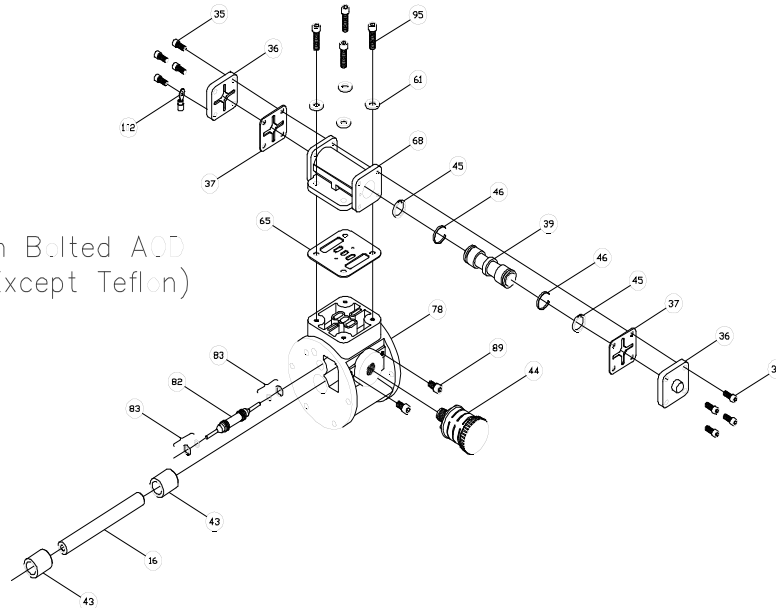

44-382-01.Wg rev. C

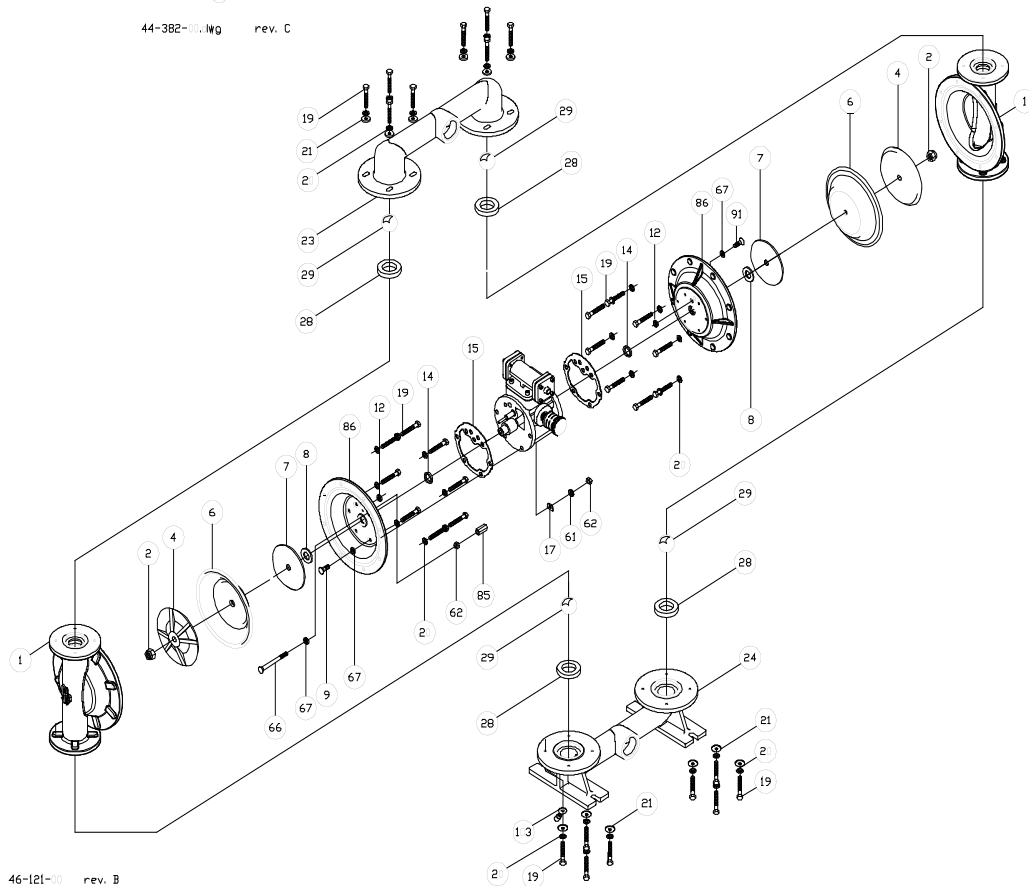

46-121-00 rev. B

Price Pump Co.

21775 Eighth Street East * Sonoma, CA 95476 * Phone (707) 938-8441 * Fax (707) 938-0764

PRICE AOD® PUMP CAUTIONS & WARNINGS

- **CAUTION:** A Static charge buildup could occur in a plastic pump or an electrically insulated metal pump.
- **WARNING:** Any contaminants in the air supply will be exhausted out the muffler to the atmosphere.
- It is recommended that all piping connections to the pump should be flexible.
- **WARNING:** Verify chemical compatibility of the pump materials of construction with the fluid being pumped before use.
- Price AOD® pumps are not designed for use in sanitary or food applications.
- Submerged Price AOD® pumps should have their exhaust piped away from the liquid level. A submerged pump may leak some air from gasketed joints. Do not submerge pumps in corrosive fluids or media.
- A pump which has stopped due to air valve ‘icing’ will restart by itself when the ice is removed or melts.
- Use only Price Pump original equipment factory replacement parts.
- **CAUTION:** Before start-up, re-torque all external fasteners to the values listed in this I&O manual supplied with the pump.
- Pump fluid temperature limits must be observed:
 - Non-Metallic pumps - 180 - 212 deg. F max. (82 - 100 deg. C) depending on pump material or elastomers.
 - Metallic pumps - 180 - 248 deg. F max. (82 - 120 deg. C) depending on elastomers.
- **CAUTION:** Do not exceed 125 psi (8.8 Bar) air inlet pressure as component damage or personal injury may result.
- Price AOD® pumps must only be operated by clean, oil free, dry compressed air.
- Shut off, bleed down and disconnect the compressed air supply before doing any maintenance or repair to the pump.
- The pump should be flushed before disassembly. The pump should be inverted (outlet at bottom) to drain properly.
- **WARNING:** A diaphragm failure could:
 - Cause the system to which the pump is connected to be pressurized up the compressed air supply line and mix air with the fluid being pumped.
 - Cause the fluid being pumped to be sprayed out through the exhaust muffler.
- **CAUTION:** Aluminum Price AOD® pumps are not suitable for use with 1, 1, 1-trichloroethane, methylene chloride or other materials containing halogenated hydrocarbons. Aluminum wetted parts can react with these solvents and explode. Consult solvent suppliers for compatibility with aluminum pumps before installation.
- **CAUTION:** For 1-1/2", 2" and 3" Price AOD® pumps, unit weight may exceed 65 lbs. (30 kg).

Price AOD® pump sound levels at a distance of 3 ft. (1 meter) with an air inlet pressure of 35 psig.

Pump Size (in Inches)	Pump Material	Sound Pressure Level (RMS db)
1/2"	Non-Metallic	82 db
1"	Non-Metallic	82 db
1"	Metallic	82 db
1-1/2"	Metallic	82 db
2"	Non-Metallic	79 db
2"	Metallic	80 db
3"	Metallic	80 db

Warning and Safety instructions - ATEX

Please observe all Warning and Safety notes



This symbol marks notes which contain safety relevant information. If this information is disregarded or the pump is operated not in accordance with the appropriate instructions, potentially dangerous situations may result which may cause harm to humans, production plants and machines.



This symbol marks notes and instructions relevant to installing and operating **E_x** approved pumps in explosion hazardous areas.

Pumps for use in hazardous areas

Pumps for use in explosion hazardous areas are marked accordingly showing the approved zone and group. If the pump is marked as shown below it can be used in hazardous areas, Zone 1 according to the current ATEX regulations. The special conditions for this operation must be strictly adhered to as outlined in the ATEX manual.



II 2 G c II T4
LU 03 ATEX M003X



The pump must be connected to earth. The wire used for this must have a cross section of not less than **4 mm²**.



The wire used to earth the pump must be connected to the Air Valve of the pump (as shown in the drawing below), and then to the earth. Prior to any installation work on the pump the earthing wire has to be connected. If the pump is being removed the earthing wire must be removed last.

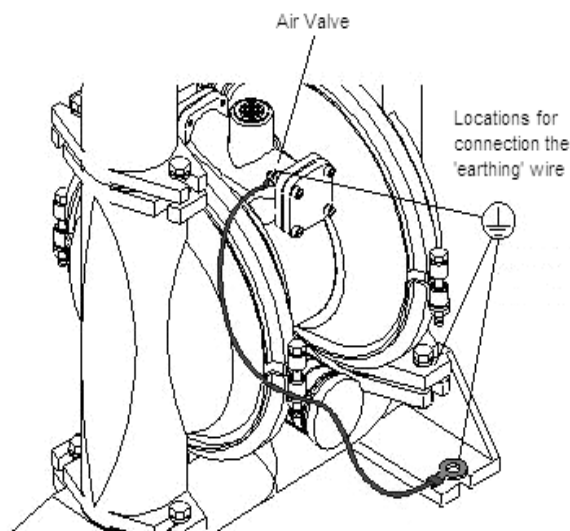

Any maintenance work on the pump should only be carried out by trained maintenance personnel.



If the pump is modified in any way, without the approval of the manufacturer, the pump may not be installed or used in hazardous areas.



PRICE PUMP



EC Declaration of Conformity / EG Konformitätserklärung / Déclaration de conformité CE

we, wir, nous

Price Pump Company
21775 Eight Street East
Sonoma CA. 95476 USA

bearing sole responsibility, hereby declare that the product:
erklären in alleiniger Verantwortung, dass das Produkt:
déclarons de notre seule responsabilité que le produit:

Air-operated double diaphragm Pump Series
Druckluftgetriebene Doppelmembranpumpe Serie
Pompe pneumatique à double membrane Série

AOD1 / AOD1.5 / AOD2 / AOD3
Aluminum, Cast iron, Stainless steel
Aluminium, Grauguss, Edelstahl
Aluminium, Fonte, Acier inox

referred to by this declaration of conformity with the following standards or normative documents
auf das sich diese Erklärung bezieht, mit der nachfolgenden Norm oder normativen Dokumente übereinstimmt
auquel se rapporte la présente déclaration est conforme aux normes ou aux documents normatifs suivants.

- EN 13463-1: 2009 Non-electrical equipment for use in potentially explosive atmospheres, basic method and requirements
EN 13463-5: 2003 Non-electrical equipment for use in potentially explosive atmospheres, protection by constructional safety
EN 14121-1: 2008 Safety of machinery Risk assessment
EN 1127-1: 2007 Explosive atmospheres. Explosion prevention and protection Basic concepts and methodology
98/37/EG Directive of the European Parliament and of the Council of 22nd June 1998 on the approximation of the laws of the Member States relating to machinery
94/9/EG Directive 94/9/EC of the European Parliament and the Council of 23rd March 1994 on the approximation of the laws of the member states concerning equipment and protective systems intended for use in potentially explosive atmospheres.

Type of protection
Zündschutzart
Mode de protection Ex
II 2G c II T4
Fördermedium Tmax. 80° C

Registry number
Registriernummer
Numéro d'enregistrement LU 03 ATEX M003X

Place: Sonoma, Ca
Ort
Lieu

Date: 20.08.2009
Datum
Date

Joe Keechler
Quality Manager
Price Pump Co.

Pawel Bankowsky
Director of Engineering
Price Pump Co.



GENERAL TERMS OF SALE

1. GENERAL

A. Seller's price is based on these sales terms and conditions. The agreement and inclusion of other or amended terms in this contract will result in a change (including increase) in Seller's price (as may be contained in any price books or quotations) to reflect such other or amended terms. This contract shall represent the final, complete and exclusive statement of the agreement between the parties and may not be modified, supplemented, explained or waived by parole evidence, any Terms and Conditions contained in Buyer's purchase order or request for quotation, any course of dealings between the parties, Seller's performance or delivery, or in any other way. The Terms and Conditions of this contract may only be modified or waived in a written document signed by an Officer of Seller. These terms are intended to cover all activity of Seller and Buyer hereunder, including sales and use of products, parts and work and all related matters (references to products include parts and references to work include construction, installation and start-up). Any reference by Seller to Buyer's specifications and similar requirements are only to describe the products and work covered hereby and no warranties or other terms therein shall have any force of effect. Any information provided by Seller including, but not limited to, suggestions as to specific equipment does not imply any guarantee of specific suitability and/or material compatibility in a particular application, since many factors outside the control of Seller may affect the suitability of products in a particular application. Catalogs, circulars, similar pamphlets and information contained on websites of the Seller are issued for general information purposes only and shall not be deemed to modify the provisions hereof.

B. The agreement formed hereby and the language herein shall be construed and enforced under the Uniform Commercial Code as in effect in the State of California on the date hereof.

2. TAXES

Any sales, use or other similar type taxes imposed on this sale or on this transaction and/or any import or export duties or fees as may be assessed or imposed on or as a result of deliveries under this transaction are not included in the price. Such taxes shall be billed separately to the Buyer. Seller will accept a valid exemption certificate from the Buyer if applicable; however, if an exemption certificate previously accepted is not recognized by the governmental taxing authority involved and the Seller is required to pay the tax covered by such exemption certificate. Buyer agrees to promptly reimburse Seller for the taxes paid.

3. PERFORMANCE, INSPECTION AND ACCEPTANCE

A. Unless Seller specifically assumes installation, construction or start-up responsibility, all products shall be finally inspected and accepted within thirty (30) days after arrival at point of delivery. Where seller has responsibility for installation, construction or start-up all work shall be finally inspected and accepted within thirty (30) days after completion of the applicable work by Seller. All claims whatsoever by Buyer, (including claims for shortages) except only those provided for under the WARRANTY AND LIMITATION OF LIABILITY and PATENTS Clauses, hereof, must be asserted in writing by Buyer within said thirty (30) day period or they are waived. If this contract involves partial performance, all such claims must be asserted within said thirty- (30) day period for each partial performance. There shall be no revocation of acceptance. Rejection may be only for defects substantially impairing the value of products or work and Buyer's remedy for lesser defects shall be those provided for under the WARRANTY AND LIMITATION OF LIABILITY Clause.

B. Seller shall not be responsible for non-performance or for delays in performance occasioned by any causes beyond Seller's reasonable control, including, by way of example and not limitation, to labor difficulties, delays of vendors or carriers, fires, governmental actions, or shortages of material, components, labor, or manufacturing facilities. Any delays so occasioned shall affect a corresponding extension of Seller's performance dates, which are, in any event, understood to be approximate. IN NO EVENT SHALL BUYER BE ENTITLED TO INCIDENTAL OR CONSEQUENTIAL DAMAGES FOR LATE PERFORMANCE OR FOR A FAILURE TO PERFORM. Seller reserves the right to make partial shipments and to ship products, parts or work which may be completed prior to the scheduled performance date.

C. In the event that Seller has agreed to mount motors, turbines, gears, or other products which are not manufactured by Seller and which are not an integral part of Seller's manufactured product, and a delay in the delivery of such products to Seller occurs that will cause a delay in Seller's performance date, Seller reserves the right to ship its product upon completion of manufacture and to refund an equitable portion of the amount originally included in the purchase price for mounting without incurring liability for non-performance.

D. Seller reserves to itself the right to change its specifications, drawings and standards if such changes will not impair the performance of its products, and parts, and further those products, and parts, will meet any of Buyer's specifications and other specific product requirements which are a part of this agreement. Seller is a global supplier of products and utilizes parts and products obtained worldwide, and Seller's products supplied under this contract shall be subject to Seller's sole determination as to all manufacturing, sourcing, assembly and supply unless otherwise specifically agreed in writing.

E. The manufacture and inspection of products and parts shall be to Seller's Engineering and Quality Assurance standards, plus such other inspections or tests of documentation as are specifically agreed to by Seller. Requirements for any additional inspection, tests, documentation, or Buyer witness of manufacture, test, and/or inspection shall be subject to additional charges.

4. TITLE AND RISK OF LOSS

Title and risk of loss shall pass to buyer upon delivery of products at the designated "Ex Works" as defined by Incoterms, unless otherwise agreed by the parties.

5. EROSION AND CORROSION

It is specifically understood that products and parts sold hereunder are not warranted for operation with erosive or corrosive fluids or for operation with any fluid or under any operating condition in variance with the specifications of this contract. No product or part shall be deemed to be defective by reason of failure to resist erosive or corrosive action of any fluid and Buyer shall have no claim whatsoever against Seller therefore. No product shall be deemed defective by reason of any effect on Seller's products of the action or results (such as vibration) of any goods or system (such as piping) not supplied by Seller.

6. BUYER'S RESPONSIBILITY

The design specifications of the equipment require the operation of the equipment within certain parameters and may call for the use of speed controls, safety devices, set points or other control devices to insure that the operation remains within design parameters. Buyer agrees and understands that the equipment must be operated and maintained within design specifications and operated within the specifications of the contract, irrespective of whether controls or devices are otherwise required.

7. WARRANTY AND LIMITATION OF LIABILITY

A. Seller warrants only that its product and parts, when shipped, will be free from defects in materials and workmanship. All claims for defective products or parts under this warranty must be made in writing immediately upon discovery and, in any event, within two (2) years of shipment by seller and all claims for defective work must be made in writing immediately upon discovery. Defective items must be held for Seller's inspection and returned to the sellers' point of original shipment upon request.

ANY UNAUTHORIZED DISSASSEMBLY, ALTERATION OF OR TAMPERING WITH ANY PRODUCT OR COMPONENT MAY "VOID" THE WARRANTY, IN THAT SUCH ACTION WILL RESULT IN SELLER BEING RELEASED AND RELIEVED FROM ITS OBLIGATIONS UNDER THIS WARRANTY AND FOR ANY FURTHER COSTS OR ACTIONS UNDER CLAUSE 7.C, FOLLOWING, AND THE BUYER ASSUMING SOLE RESPONSIBILITY FOR THE COSTS AND RESULTS OF SUCH ACTION. THE FOREGOING IS EXPRESSLY IN LIEU OF ALL OTHER WARRANTIES WHATSOEVER, EXPRESS, IMPLIED AND STATUTORY, INCLUDING WITHOUT LIMITATION, THE IMPLIED, WARRANTIES OF MERCHANTABILITY AND FITNESS.

B. ANY PRODUCT (S) SOLD HEREUNDER WHICH ARE NOT MANUFACTURED BY SELLER ARE NOT WARRANTED BY SELLER and shall be covered only by the express warranty, if any, of the manufacturer thereof. With respect to products and parts not manufactured by Seller, Seller's only obligation shall be to assign to Buyer, to the extent possible, whatever warranty Seller obtains from the manufacturer.

C. Upon Buyer's submission of a claim as provided above and its substantiation, Seller shall at its option either (i) repair or replace its product, part or work at the original place of shipment, or (ii) refund an equitable portion of the purchase price.

D. THE FOREGOING IS SELLER'S ONLY OBLIGATION AND BUYER'S EXCLUSIVE REMEDY FOR BREACH OF WARRANTY AND, EXCEPT FOR THE REMEDIES PERMITTED UNDER THE PERFORMANCE, INSPECTION AND ACCEPTANCE AND THE PATENTS CLAUSES HEREOF, THE FOREGOING IS BUYER EXCLUSIVE REMEDY AGAINST SELLER FOR ALL CLAIMS ARISING HEREUNDER OR RELATING HERETO WHETHER SUCH CLAIMS ARE BASED ON BREACH OF CONTRACT, TORT (INCLUDING NEGLIGENCE OR STRICT LIABILITY), INDEMNITY OR OTHER THEORIES. BUYER'S FAILURE TO SUBMIT A CLAIM AS PROVIDED ABOVE SHALL SPECIFICALLY WAIVE ALL CLAIMS FOR DAMAGES OR OTHER RELIEF, INCLUDING BUT NOT LIMITED TO CLAIMS BASED ON LATENT DEFECTS. IN NO EVENT SHALL BUYER BE ENTITLED TO INDIRECT, SPECIAL, INCIDENTAL OR CONSEQUENTIAL DAMAGES, NOR FOR DAMAGES FOR LOSS OF USE, LOST PROFITS OR REVENUE, INTEREST, LOST GOODWILL, WORK OR PRODUCTION STOPPAGE, IMPAIRMENT OF OTHER GOODS, INCREASED EXPENSES OF OPERATION, OR THE COST OF PURCHASING REPLACEMENT POWER OR OTHER SERVICES BECAUSE OF SERVICE INTERRUPTIONS. FURTHERMORE, IN NO EVENT SHALL SELLER'S TOTAL LIABILITY FOR DAMAGES OF BUYER EXCEED THE PURCHASE PRICE OF THE PRODUCTS OR PARTS MANUFACTURED BY SELLER AND UPON WHICH SUCH LIABILITY IS BASED. ANY ACTION ARISING HEREUNDER RELATED HERETO, WHETHER BASED ON BREACH OF CONTRACT, TORT (INCLUDING NEGLIGENCE) OR OTHER THEORIES, MUST BE COMMENCED WITHIN ONE (1) YEAR AFTER THE CAUSE OF ACTION ACCRUES OR IT SHALL BE BARRED.

8. PURCHASER'S REPRESENTATIONS & WARRANTIES

Purchaser represents and warrants that the products(s) covered by this contract shall not be used in or in connection with a nuclear facility or application. The parties agree that this representation and warranty is material and is being relied on by seller. This provision may be modified in a separate writing signed by an officer of Price Pump Co.

9. PATENTS

Seller agrees to assume the defense of any suit for infringement of any patents brought against Buyer to the extent of such suit charges infringement of an apparatus or product claim by Seller's product in and of itself, provided (i) said product is built entirely to Seller's design, (ii) Buyer notifies Seller in writing of the filing of such suit within ten (10) days after the service of process thereof, and (iii) Seller is given complete control of the defense of such suit, including the right to defend, settle and make changes in the product for the purpose of avoiding infringement of any process or method claims. Provided however, Seller will not defend any suit for infringement of a claimed patent where such alleged infringement is the result of following specific instruction furnished by Seller.

10. EXTENT OF SUPPLY

Only products as listed in Seller's proposal are included in this agreement. It must not be assumed that Seller has included anything beyond same.

11. MANUFACTURING SOURCES

To maintain delivery schedules, Seller reserves the right to have all or any part of the Buyer's order manufactured at any of Sellers', sellers' licensees or sub contractors' plants, globally.

12. TERMS OF PAYMENT

Net 30 days from date of invoice.

13. ARBITRATION

In the event a dispute arises between the parties relating to or arising out of this agreement, the parties agree to attempt to have their senior management amicably settle the matter. In the event that the matter cannot be settled, the parties shall submit all disputes relating to this Agreement (whether contract, tort, products liability or otherwise) to binding Arbitration before a panel of arbitrators under the Commercial Dispute Resolution Procedures of the American Arbitration Association. Each party shall appoint an arbitrator and the third shall be selected in accordance with the rules of the American Arbitration Association. Judgment upon the award may be entered in any court having jurisdiction. The parties shall cooperate in providing reasonable disclosure of relevant documents. Each party shall bear its own expenses, and the costs and fees of the arbitration shall be borne as allocated by the Arbitrator.