



Price® Pump Co.

---

# INSTALLATION, OPERATING AND MAINTENANCE MANUAL

AIR OPERATED DIAPHRAGM PUMPS  
MOM-METALLIC, ALL ELASTOMERS

MODEL AOD1.5-Y

PLEASE FILL PUMP DATA FROM NAMEPLATE

Pump Model\_\_\_\_\_

Spec. No.\_\_\_\_\_

Serial No.\_\_\_\_\_

Seal No.\_\_\_\_\_

RETAIN MANUAL FOR REFERENCE

Price® Pump Company  
21775 8th. Street East  
Sonoma, CA 95476  
Tel: 707-938-8441  
Fax 707-938-0764  
Email: sales@pricepump.com

## WARNING



- For your own safety, be sure to read these procedures carefully before performing maintenance on this product. After reading this document, be sure to keep it handy for future reference.

This edition is based on the standards for the March 2009 production run. Remember, the specifications are always subject to change; therefore, some of the information in this edition may not apply to new specifications.

### Warnings and Cautions

For safe use of this product, be sure to note the following: In this document, warnings and cautions are indicated by symbols. These symbols are for those who will operate this product and for those who will be nearby, for safe operation and for prevention of personal injury and property damage. The following warning and caution symbols have the meanings described below. Be sure to remember their meanings.



**WARNING :** If you ignore the warning described and operate the product in an improper manner, there is danger of serious bodily injury or death.



**CAUTION :** If you ignore the caution described and operate the product in an improper manner, there is danger of personal injury or property damage.

Furthermore, to indicate the type of danger and damage, the following symbols are also used along with those mentioned above:



This symbol indicates a DON'T, and will be accompanied by an explanation on something you must not do.



This symbol indicates a DO, and will be accompanied by instructions on something you must do in a certain situation.

## WARNING



- Before starting maintenance work, cut off the feed air and clean the pump. If air pressure or residue remain in the pump, there is danger of explosion, or possible poisoning resulting in serious injury or death if chemicals adhere to the skin or are accidentally swallowed. (For details on cleaning the pump, refer to Chapter 6 of the operating manual.)
- When replacing parts, be sure to use the recommended genuine parts or Equivalents. Use of other parts may cause a malfunction of the product.

## CAUTION



- When it is instructed that special tools must be used, be sure to use the specified tools. Otherwise, the pump may be damaged.
- Refer to 10.1 "Specifications" in the Operating Manual. Also, remember that the pump is heavy, and extreme care must be taken when lifting it.

## Table of Contents

|   |    |
|---|----|
| <b>Warnings and Cautions</b> .....                | 1  |
| <b>Table of Contents</b> .....                    | 2  |
| <b>1. Principle of operation</b> .....            | 3  |
| <b>2. Tools, etc.</b>                             |    |
| 2.1 General tools .....                           | 3  |
| 2.2 Special Tools .....                           | 3  |
| 2.3 Misc. ....                                    | 3  |
| <b>3. Ordering Replacement Parts</b> .....        | 3  |
| <b>4. Balls, Flat valves and Valve Seats</b>      |    |
| 4.1 Removal .....                                 | 4  |
| 4.2 Inspection .....                              | 5  |
| 4.3 Installation .....                            | 5  |
| <b>5. Diaphragm and Center rod</b>                |    |
| 5.1 Removal .....                                 | 6  |
| 5.2 Inspection .....                              | 7  |
| 5.3 Installation                                  |    |
| BPC, BPN, BPE, BPV, BPH, BPS types .....          | 7  |
| BPT type .....                                    | 8  |
| <b>6. Throat bearing and Pilot valve Assembly</b> |    |
| 6.1 Removal .....                                 | 9  |
| 6.2 Checking .....                                | 9  |
| 6.3 Installation .....                            | 9  |
| <b>7. C-Spool valve assembly</b>                  |    |
| 7.1 Removal .....                                 | 10 |
| 7.2 Checking .....                                | 11 |
| 7.3 Installation .....                            | 11 |
| <b>8. Exploded View and Parts List</b>            |    |
| 8.1 EXPLODED VIEW .....                           | 12 |
| 8.2 PARTS LIST, COMMON PARTS .....                | 14 |
| 8.3 EXPLODED VIEW, BODY ASSEMBLY.....             | 15 |
| 8.4 PARTS LIST, BODY ASSEMBLY .....               | 15 |
| 8.5 EXPLODED VIEW, BODY ASSEMBLY .....            | 16 |
| 8.6 PARTS LIST, VALVE BODY ASSEMBLY .....         | 16 |



## ■ NDP-40 BP\_·BV\_ type

See [9. Exploded View] on after p. 13.

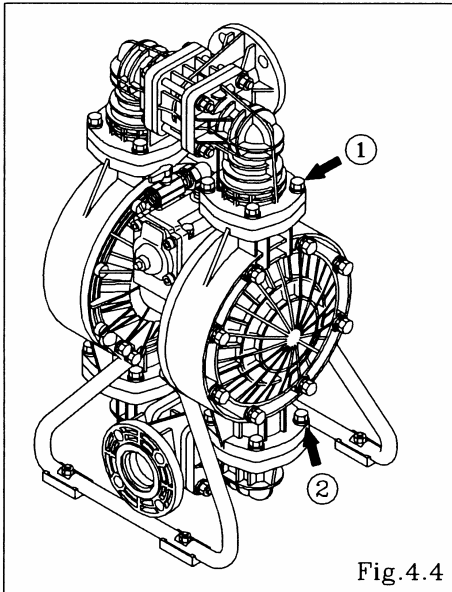

- Remove the 8 retainer bolts "1" from the out manifold, and remove the out manifold. [Fig.4.4]

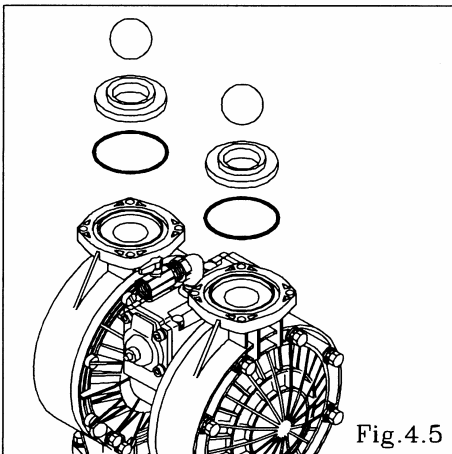

- Remove the ball, valve seat and O ring. [Fig.4.5]

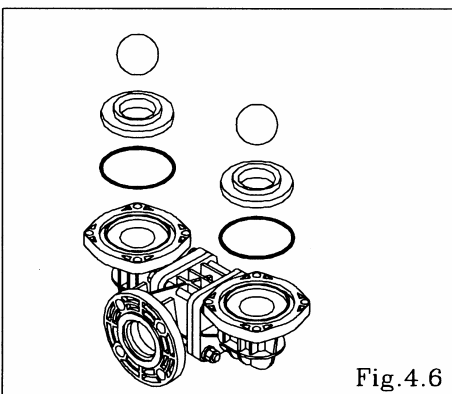

- Remove the 8 retainer bolts "2" from the in manifold, and remove the in manifold. [Fig.4.4]
- Remove the ball, valve seat and O ring. [Fig.4.6]

## 4.2 Inspection

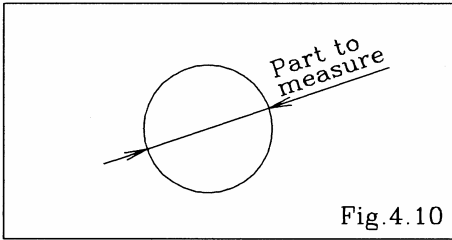

- Ball [Fig.4.10]  
Measure the outside diameter, and if it is outside the usable range, replace the ball.

Usable range of ball

|        |  |
|--------|--|
| NDP-40 | Sø1.772 ~ Sø2.028 in<br>{Sø45.0 ~ Sø51.5 mm} |
|--------|--|

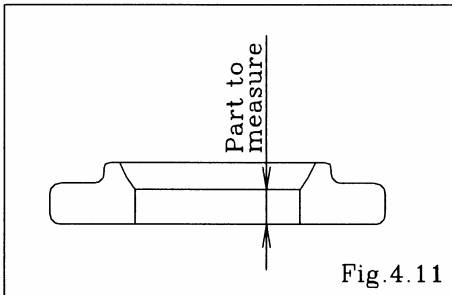

- Valve seat [Fig.4.11]  
Measure the dimension shown at left, and if it is outside the usable range, replace the seat.

Usable range of valve seat

|        | B_C, B_N, B_E<br>B_V, B_H, B_S      | B_T                                |
|--------|-------------------------------------|------------------------------------|
| NDP-40 | 0.181 ~ 0.453 in<br>{4.6 ~ 11.5 mm} | 0.067 ~ 0.161 in<br>{1.7 ~ 4.1 mm} |

- O ring (other than PTFE)  
If O ring is worn out or cracked, replace it.

## 4.3 Installation

For installation, see [9. Exploded View] on after p. 13, and install in the reverse order of disassembly.

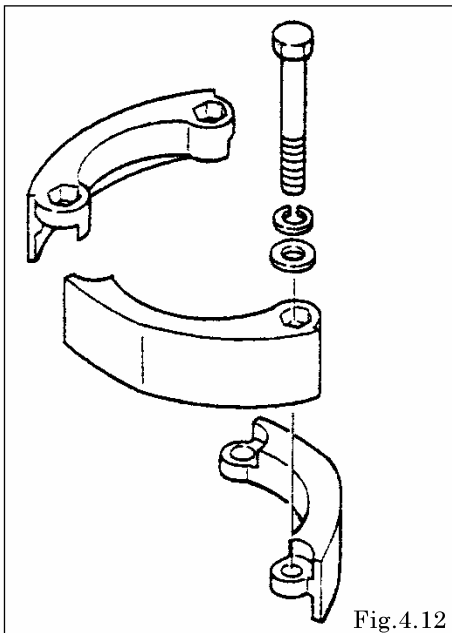

Tightening torque for manifold retainer bolts

15 ft-lbf {20 N-m}

<NOTE>

- Make sure there is no dust on the seal surface and the seal is not damaged.
- Replace the PTFE O ring regardless of its condition.
- Match the convex and concave parts of the protector.

## 5. Diaphragm and Center rod

### 5.1 Removal

#### ■BA\_, BS\_, BF\_ types

See [9. Exploded View] on after p. 13.

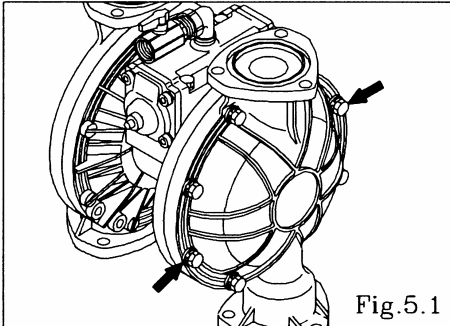

- Remove the ball and valve seat etc. (see [ 4.1 Removal BA\_, BS\_, BF\_ types] on p. 2)

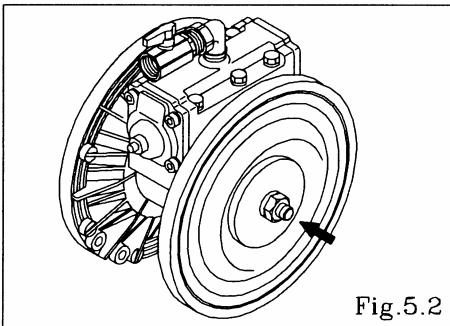

- Remove the nuts on both sides of the center rod. [Fig.5.2]
- After the nut on one side have been removed, remove the center disk and diaphragm. Remove the diaphragm, center disk and center rod from the opposite side of the main body.

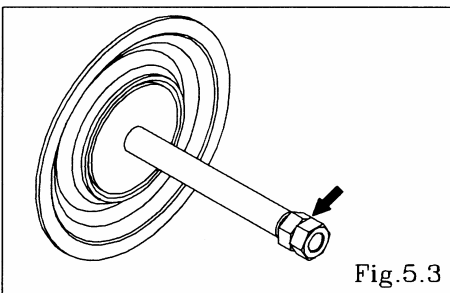

- Remove the nut on the opposite side using the double nut. [Fig.5.3]
- Remove the coned disk spring, center disk and diaphragm.

#### ■BP\_, BV\_ types

See [9. Exploded View] on after p. 13. (Fig. 5.4 shows the NDP-40 BP\_.)

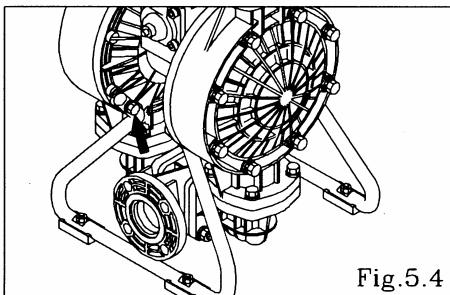

- Remove the ball etc. (see [ 4.1 Removal BP\_, BV\_ types] on pp. 5-6)
- Remove the 8 (4 on the NDP-40) retainer bolts from the stand body, and remove the stand body. [Fig.5.4]

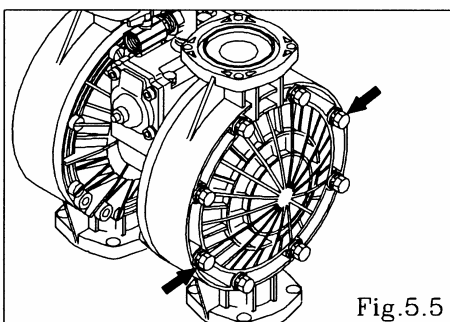

- Remove the 16 retainer bolts from the out chamber, and remove the out chamber. [Fig.5.5]

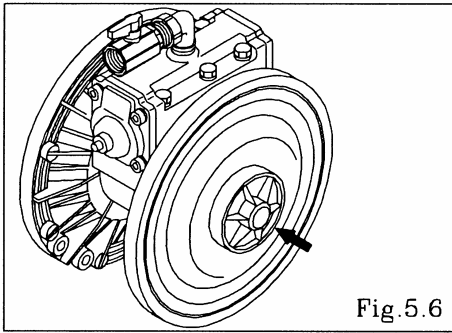

Fig.5.6

- Remove the center disk from one side using the PP wrench (special tool: Part No. 771868). [Fig.5.6]
- After the center disk (outside) has been removed, remove the diaphragm and the center disk (inside). Remove the center disk and center rod from the opposite side of the main body.

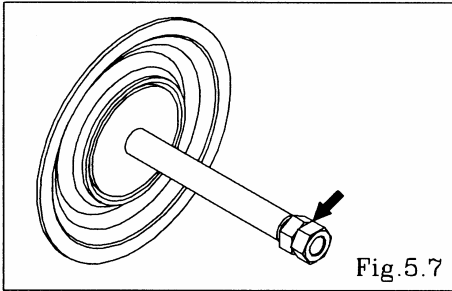

Fig.5.7

- Fix a double nut to one end of the center rod and take the diaphragm and center disk off the opposite end. [Fig.5.9] Be careful not to scratch or score the center rod.

## 5.2 Inspection

- Diaphragm  
If the diaphragm is worn out or damaged, replace it. New replace just one diaphragm.

Guideline of diaphragm life

|               |                  |
|---------------|------------------|
| CR, NBR, EPDM | 10,000,000 cycle |
| FKM           | 2,500,000 cycle  |
| PTFE          | 3,000,000 cycle  |
| TPEE, TPO     | 15,000,000 cycle |

(When used with clean water at room temperature)

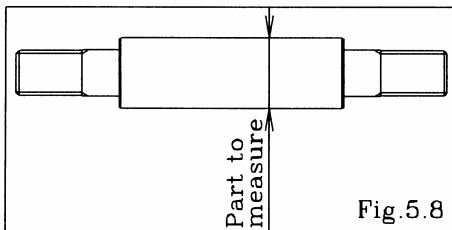

Fig.5.8

- Center rod [Fig.5.8]  
Measure the diameter, and if it is outside the usable range, replace the rod.

Usable range of center rod

|  |
|--|
| $\varnothing 0.9815 \sim \varnothing 0.9843$ in { $\varnothing 24.93 \sim \varnothing 25.00$ mm} |
|--|

## 5.3 Installation

### ■ B\_C, B\_N, B\_E, B\_V, B\_H, B\_S types

For installation, see [9. Exploded View] on after p. 13, and install in the reverse order of disassembly.

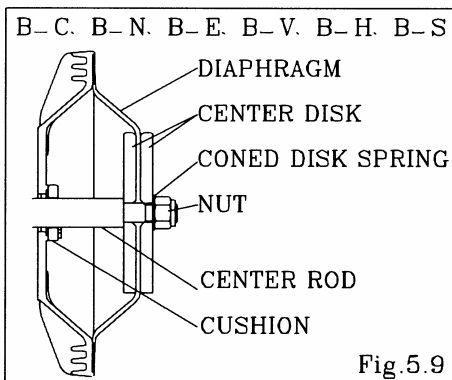

Fig.5.9

- Apply assembly grease to the center rod, and insert it into the main body.
- Insert the cushion (except with the NDP-80). (cf. Fig.5.9)
- Keep the marking "OUTSIDE" to liquid end for CR, NBR, EPDM, FKM diaphragms. Keep the convex side to the outside for TPEE, TPO diaphragms.
- Tighten the center disk using the PP wrench (special tool: Part No.771868) for the BP\_, BV\_ types. Apply proper Thread locker to the thread of center disk. (No coned disk springs and nuts are needed.)

Tightening torque for center rod

|               |                    |
|---------------|--------------------|
| BA_, BS_, BF_ | 43 ft-lbf {60 N-m} |
| BP_, BV_      | 36 ft-lbf {50 N-m} |



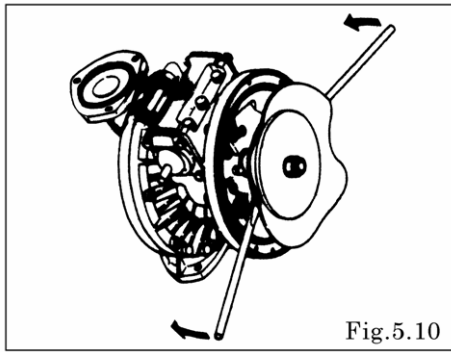

Fig.5.10

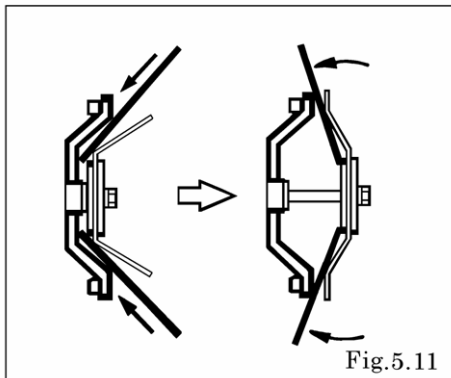

Fig.5.11

- Draw the center disk to one side (exclude B\_H, B\_S type cf. Fig. 5.9).
- And install the out chamber. Tighten the bolts temporarily.
- Grip the inside center disk using crowbars and draw it to the opposite side, then turn the diaphragm over. (exclude B\_H, B\_S type) [Fig. 5.10, 5.11]
- And install the out chamber. Tighten the bolts temporarily.
- After installation of the out chambers on both sides, place the pump on a flat surface and stand the pump upright for further assembly.

Tightening torque for out chamber.

|               |                    |
|---------------|--------------------|
| BA_, BS_, BF_ | 29 ft-lbf {40 N-m} |
| BP_, BV_      | 26 ft-lbf {35 N-m} |

<NOTE>

- Make sure there is no dust on the seal surface in order to prevent seal damaged.
- Be careful not to damage the R portion of the air chamber using a crowbar, etc.
- Tighten the bolts gradually in a diagonal sequence with even torque. (cf. Fig. 5.12)

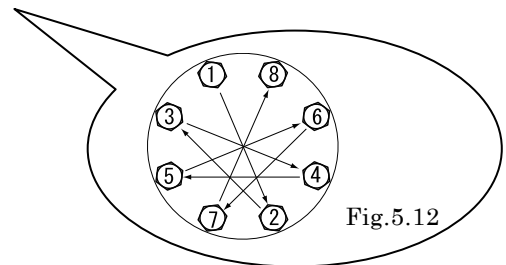

Fig.5.12

## ■ B\_T type

For installation, see [9. Exploded View] on after p. 13, and install in the reverse order of disassembly.

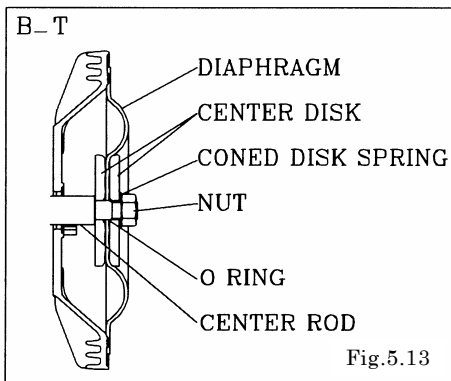

Fig.5.13

- Apply assembly grease to the center rod, and insert it into the main body.
- Keep the convex side to the outside (cf. Fig. 5.13).
- Put the O rings to both sides of the diaphragm. (cf. Fig. 5.13)
- Tighten the center disk using the PP wrench (special tool: Part No. 771868) for the BPT, BVT type. Apply proper Thread locker to the thread of center disk. (No coned disk springs and nuts are needed.)

Tightening torque for center rod

|               |                    |
|---------------|--------------------|
| BAT, BST, BFT | 43 ft-lbf {60 N-m} |
| BPT, BVT      | 36 ft-lbf {50 N-m} |

- Tighten the out chamber temporarily at first. After installation of the out chambers on both sides, place the pump on a flat surface and stand the pump upright for further assembly.

Tightening torque for out chamber

|               |                    |
|---------------|--------------------|
| BAT, BST, BFT | 29 ft-lbf {40 N-m} |
| BPT, BVT      | 26 ft-lbf {35 N-m} |

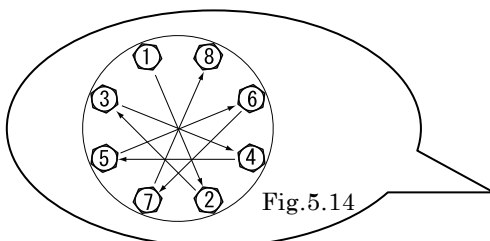

Fig.5.14

<NOTE>

- Make sure there is no dust on the seal surface in order to prevent seal damaged.
- Replace the PTFE O ring by new one.
- Tighten the bolts gradually in a diagonal sequence with even torque. (cf. Fig. 5.14)

## 6. Throat bearing and Pilot valve

### 6.1 Removal

See [9. Exploded View] on after p. 13.

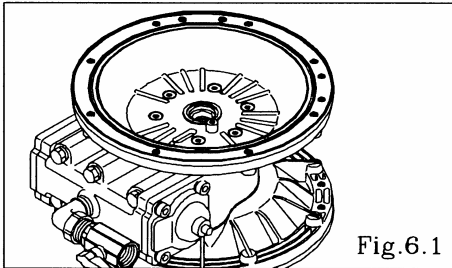

- Remove the diaphragm and center rod (see [5.1 Removal] on pp. 6-7).
- Remove the 12 retainer bolts from the air chamber, and remove the air chamber. [Fig.6.1]

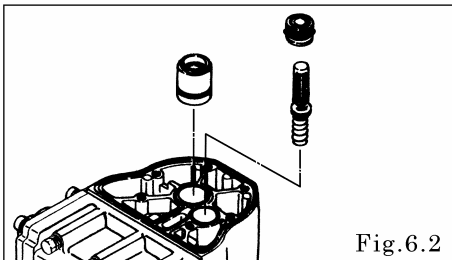

- Draw out the pilot valve and valve seat. [Fig.6.2]
- Draw out the throat bearing. [Fig.6.2]

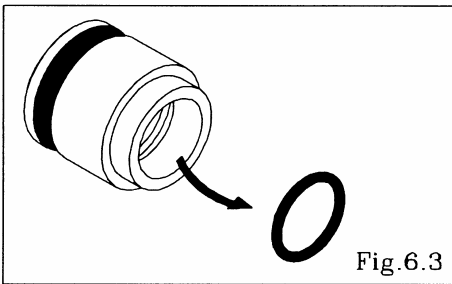

- Remove the packing from the throat bearing. [Fig.6.3]

### 6.2 Inspection

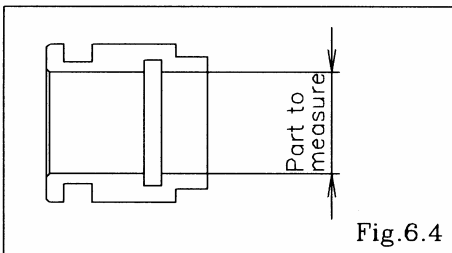

- Throat bearing [Fig.6.4]  
Measure the inside diameter, and if it is outside the usable range, replace the throat bearing

Usable range of throat bearing

$\varnothing 0.9859 \sim \varnothing 0.9894$  in { $\varnothing 25.04 \sim \varnothing 25.13$  mm}

- O ring, Packing  
If the O ring is worn out or cracked, replace it.
- Pilot valve  
If the pilot valve is worn out or cracked, replace it.

### 6.3 Installation

For installation, see [9. Exploded View] on after p. 13, and install in the reverse order of disassembly.

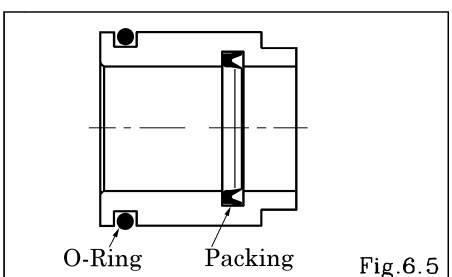

Tightening torque for air chamber retainer bolts

15 ft-lbf {20 N-m}

<NOTE>

- Make sure there is no dust on the seal surface and the seal is not damaged.
- Apply grease to packing.

## 7. C spool valve assembly

### 7.1 Removal

See [9. Exploded View] on after p. 13.

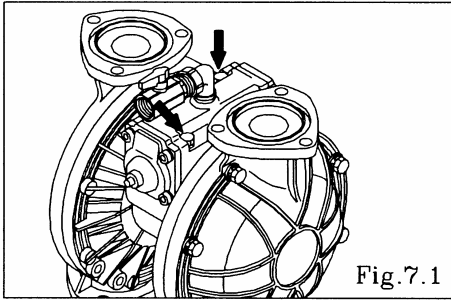

- Remove the out manifold (see 4.1 Removal on pp. 2, 3-4).
- Remove the 6 retainer bolts from the valve body, and remove the valve body. [Fig. 7.1]

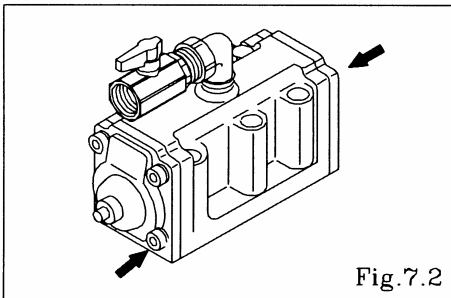

- Remove the 8 cap A and cap B retainer bolts, and remove cap A and cap B. [Fig. 7.2]

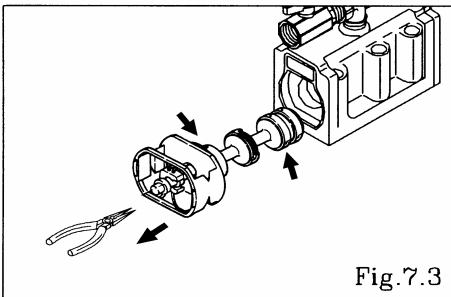

- Draw out the C spool valve assembly, and remove the seal ring from the C spool valve assembly.
- Remove the spring stopper. [Fig. 7.3]

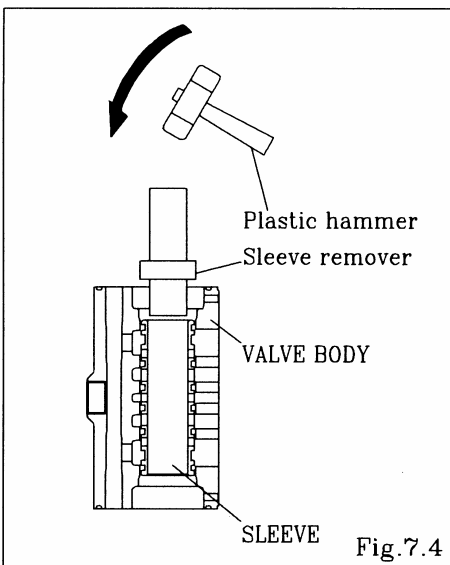

- Remove the sleeve using the sleeve remover (special tool: Part number 713180). [Fig. 7.4]

## 7.2 Inspection

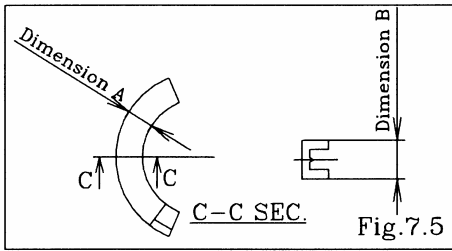

- C Spool Valve Assembly
- Seal ring [Fig.7.5]  
Measure dimensions A and B, and if there is sufficient wear to require replacement, replace the c spool valve assembly.  
If the seal ring is worn out or cracked, replace c spool valve assembly.

|             |                               |
|-------------|-------------------------------|
| Dimension A | More than 0.1988 in {5.05 mm} |
| Dimension B | More than 0.2874 in {7.30 mm} |

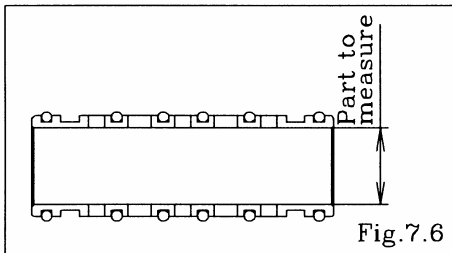

- Sleeve Assembly[Fig.7.6]  
Measure the inside diameter, and if it is outside the usable range, replace the c spool valve assembly.

|  |
|--|
| Usable range of sleeve   |
| $\varnothing 1.305 \sim \varnothing 1.313$ in { $\varnothing 33.15 \sim \varnothing 33.35$ mm} |

- O ring  
If the O ring is worn out or cracked, replace it.

<NOTE>

- C Spool Valve Assembly must be replaced as a complete set.  
Unable to replace individual component.

## 7.3 Installation

For installation, see [9. Exploded View] on after p. 13, and install in the reverse order of disassembly.

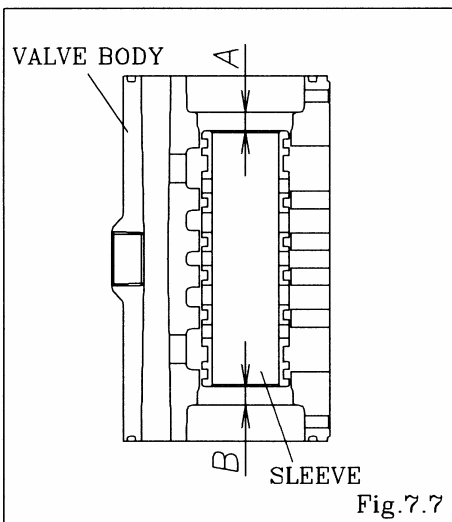

- Install the sleeve using the sleeve remover (special tool: Part No. 713180). At this point, apply assembly oil around the sleeve and O ring.
- Install the sleeve at the center of the valve body.  
(A = B)

|   |
|---|
| Tightening torque for installation cap A, cap B |
| 8 ft-lbf {10 N-m}                               |

|   |
|---|
| Tightening torque for valve body installation bolts |
| 12 ft-lbf {17 N-m}                                  |

<NOTE>

- Make sure there is no dust on the seal surface and it is not damaged.

## 8. Retightening of Tie rods

### ■ Plastic type

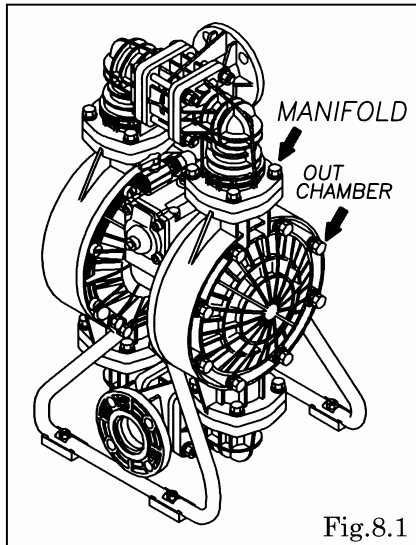

Fig.8.1

- All bolts should be retorqued:
  - (1) Right before start up.
  - (2) There are any leaks of material on daily inspecting a pump.

|        |     | Retain bolts for the out chamber | Retain bolts for the manifold |
|--------|-----|----------------------------------|-------------------------------|
| NDP-40 | BP_ | 26 ft-lbf {35 N-m}               | 15 ft-lbf {20 N-m}            |
| NDP-40 | BV_ |                                  |                               |

<NOTE>

- Retighten the Out chamber and then the manifold in this order. [Fig.8.1]
- Tighten the bolts in the order shown. [Fig.8.2]

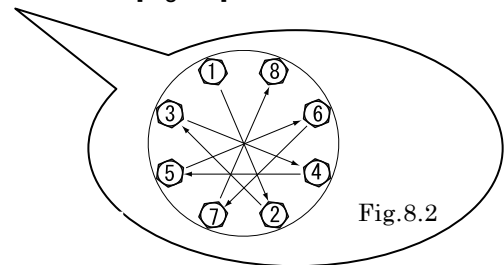
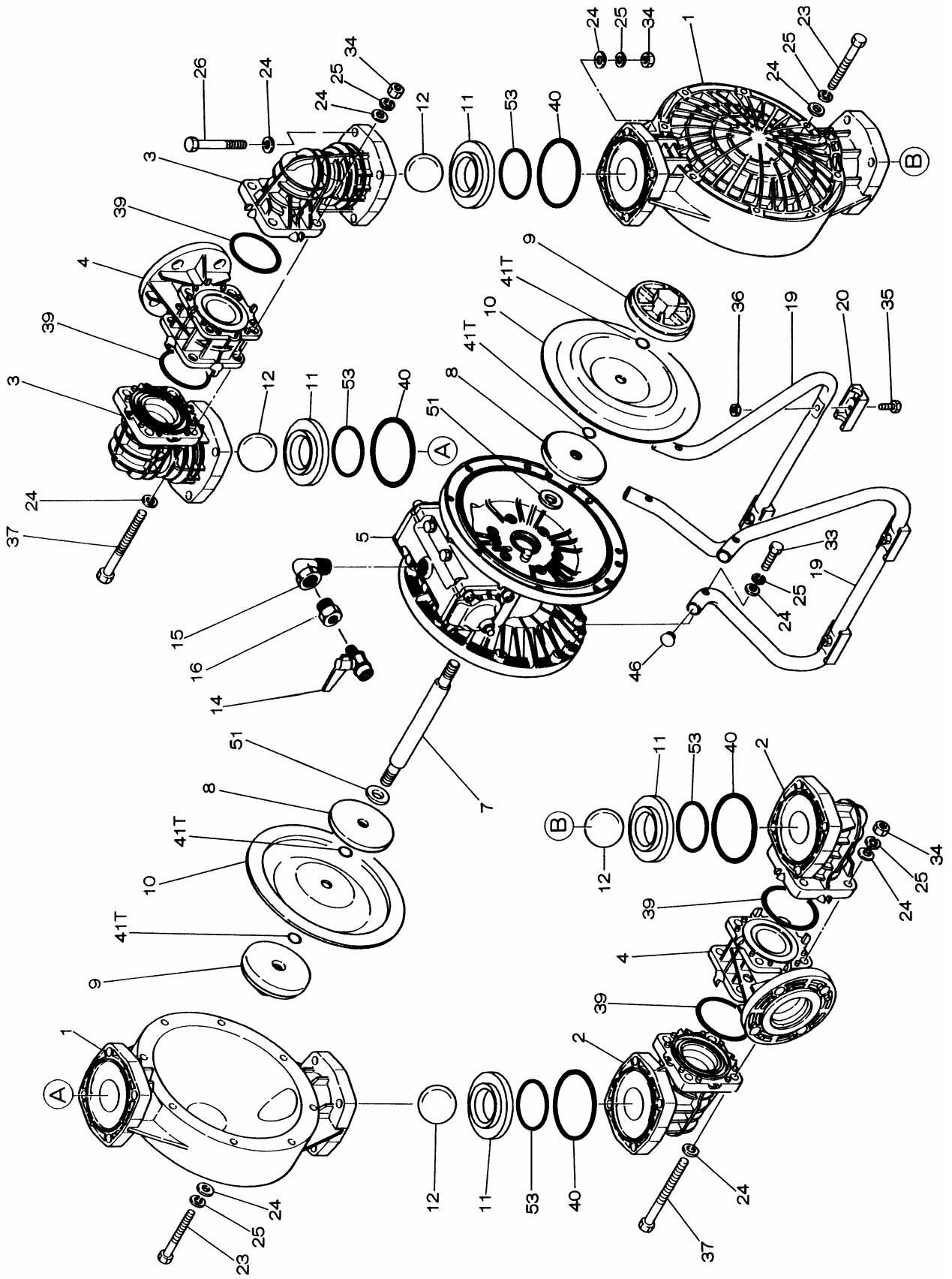

Fig.8.2

### 9.3 Exploded View

■NDP- 40BP\_ ,BV\_



9.3 Parts List

■ NDP- 40BP\_,BV\_

| NO. | BP_    | BV_    | DESCRIPTION        | Q'TY | NOTE           |
|-----|--------|--------|--------------------|------|----------------|
| 1   | 780147 | 780257 | OUT CHAMBER        | 2    |                |
| 2   | 780244 | 780251 | IN MANIFOLD        | 2    |                |
| 3   | 780150 | 780258 | OUT MANIFOLD       | 2    |                |
| 4   | 780248 | 780216 | CENTER MANIFOLD    | 2    |                |
| 5   | 803117 | 803117 | BODY ASSEMBLY      | 1    |                |
| 7   | 711900 | 711900 | CENTER ROD         | 1    |                |
| 7T  | 711939 | 711939 | CENTER ROD         | 1    |                |
| 8   | 711902 | 711902 | CENTER DISK        | 2    |                |
| 8T  | 707817 | 707817 | CENTER DISK        | 2    |                |
| 9   | 771725 | 772730 | CENTER DISK        | 2    |                |
| 9T  | 771726 | 780207 | CENTER DISK        | 2    |                |
| 10  | Tab.1  | Tab.2  | DIAPHRAGM          | 2    |                |
| 11  | 772096 | 772739 | VALVE SEAT         | 4    |                |
| 12  | Tab.4  | 770692 | BALL               | 4    |                |
| 14  | 684321 | 684321 | BALL VALVE         | 1    | 1/2"           |
| 15  | 682523 | 682523 | ELBOW              | 1    | 3/4"           |
| 16  | 684339 | 684339 | BUSHING            | 1    | 3/4"x1/2"      |
| 19  | 711925 | 711925 | STAND BODY         | 2    |                |
| 20  | 771865 | 771865 | CUSHION            | 4    |                |
| 23  | 686156 | 686156 | BOLT               | 16   | M10x1.5x105    |
| 24  | 631330 | 631330 | PLAIN WASHER       | 68   |                |
| 25  | 680257 | 680257 | SPRING LOCK WASHER | 44   |                |
| 26  | 621183 | 621183 | BOLT               | 16   | M10x1.5x60     |
| 33  | 621179 | 621179 | BOLT               | 4    | M10 × 1.5 × 40 |
| 34  | 628013 | 628013 | NUT                | 24   | M10x1.5        |
| 35  | 621149 | 621149 | BOLT               | 4    | M8x1.25x25     |
| 36  | 683837 | 683837 | NUT WITH FLANGE    | 4    | M8x1.25        |
| 37  | 683542 | 683542 | BOLT               | 8    | M10x1.5x120    |
| 39  | Tab.7  | 643060 | O RING             | 4    |                |
| 40  | Tab.8  | 643064 | O RING             | 4    |                |
| 41T | 643015 | 643015 | O RING             | 4    | P16 PTFE       |
| 46  | 683641 | 683641 | CAP                | 4    |                |
| 50  | 790911 | 790911 | NAME PLATE         | 1    |                |
| 51  | 770582 | 770582 | CUSHION            | 2    | EXCLUDED BPT   |
| 53  | Tab.11 | 643136 | O RING             | 4    |                |

NOTE 1)T : BPT

2)Tab.1~Tab.11 : SEE [9.8 PARTS LIST"COMMON PARTS"]

3)NO.50(NAME PLATE) IS NOT INDICATED IN EXPLODED VIEW

**9.8 Parts List**

**COMMON PARTS**

**Tab.1 DIAPHRAGM**

[BA\_,BS\_,BF\_,BP\_]

| TYPE | NDP-40 |
|------|--------|
| B_C  | 771853 |
| B_N  | 771700 |
| B_E  | 771854 |
| B_V  | 771799 |
| B_T  | 770814 |
| B_H  | 771701 |
| B_S  | 771975 |

| MATERIAL |
|----------|
| CR       |
| NBR      |
| EPDM     |
| FKM      |
| PTFE     |
| TPEE     |
| TPO      |

**Tab.3 VALVE SEAT**

[BA\_,BS\_,BF\_]

| TYPE | NDP-40 |        |
|------|--------|--------|
|      | BA_    | BS/BF_ |
| B_C  | 771956 | 771956 |
| B_N  | 771994 | 771994 |
| B_E  | 771921 | 771921 |
| B_V  | 771997 | 771997 |
| B_T  | 712382 | /      |
|      | /      | 711908 |
| B_H  | 771793 | 771793 |
| B_S  | 772003 | 772003 |

| MATERIAL |
|----------|
| CR       |
| NBR      |
| EPDM     |
| FKM      |
| A5056    |
| SS316    |
| TPEE     |
| TPO      |

**Tab.4 BALL**

[BA\_,BS\_,BF\_,BP\_]

| TYPE | NDP-40 |
|------|--------|
| B_C  | 770550 |
| B_N  | 770584 |
| B_E  | 770593 |
| B_V  | 770602 |
| B_T  | 770692 |
| B_H  | 770584 |
| B_S  | 770593 |

| MATERIAL |
|----------|
| CR       |
| NBR      |
| EPDM     |
| FKM      |
| PTFE     |
| NBR      |
| EPDM     |

**Tab.6 NUT(M16x1.5)**

[BA\_,BS\_,BF\_]

| TYPE | NDP-40 |
|------|--------|
| B_C  | 683408 |
| B_N  | 683408 |
| B_E  | 683408 |
| B_V  | 706128 |
| B_T  | 706128 |
| B_H  | 683408 |
| B_S  | 683408 |

| MATERIAL |
|----------|
| PA,SS316 |
| PA,SS316 |
| PA,SS316 |
| SS316    |
| SS316    |
| PA,SS316 |
| PA,SS316 |



Tab.7 O RING

| TYPE | NDP-40 |  |
|------|--------|--|
|      | BP□    |  |
|      | P70    |  |
| B□C  | 640060 |  |
| B□N  | 640060 |  |
| B□E  | 683998 |  |
| B□V  | 642060 |  |
| B□T  | 643060 |  |
| B□H  | 640060 |  |
| B□S  | 683998 |  |

| MATERIAL |
|----------|
| NBR      |
| NBR      |
| EPDM     |
| FKM      |
| PTFE     |
| NBR      |
| EPDM     |

Tab.8 O RING

| TYPE | NDP-40    |        |
|------|-----------|--------|
|      | BA/BS/BF□ | BP□    |
|      | P90       | P85    |
| B□C  | 640065    | 640064 |
| B□N  | 640065    | 640064 |
| B□E  | 683999    | 684121 |
| B□V  | 642065    | 642064 |
| B□T  | 643065    | 643064 |
| B□H  | 640065    | 640064 |
| B□S  | 683999    | 684121 |

| MATERIAL |
|----------|
| NBR      |
| NBR      |
| EPDM     |
| FKM      |
| PTFE     |
| NBR      |
| EPDM     |

Tab.11 O RING

| TYPE | NDP-40 |  |
|------|--------|--|
|      | BP□    |  |
|      | G55    |  |
| B□C  | 640136 |  |
| B□N  | 640136 |  |
| B□E  | 685447 |  |
| B□V  | 642136 |  |
| B□T  | 643136 |  |
| B□H  | 640136 |  |
| B□S  | 685447 |  |

| MATERIAL |
|----------|
| NBR      |
| NBR      |
| EPDM     |
| FKM      |
| PTFE     |
| NBR      |
| EPDM     |

### 9.9 Exploded View

### ■ BODY ASSEMBLY

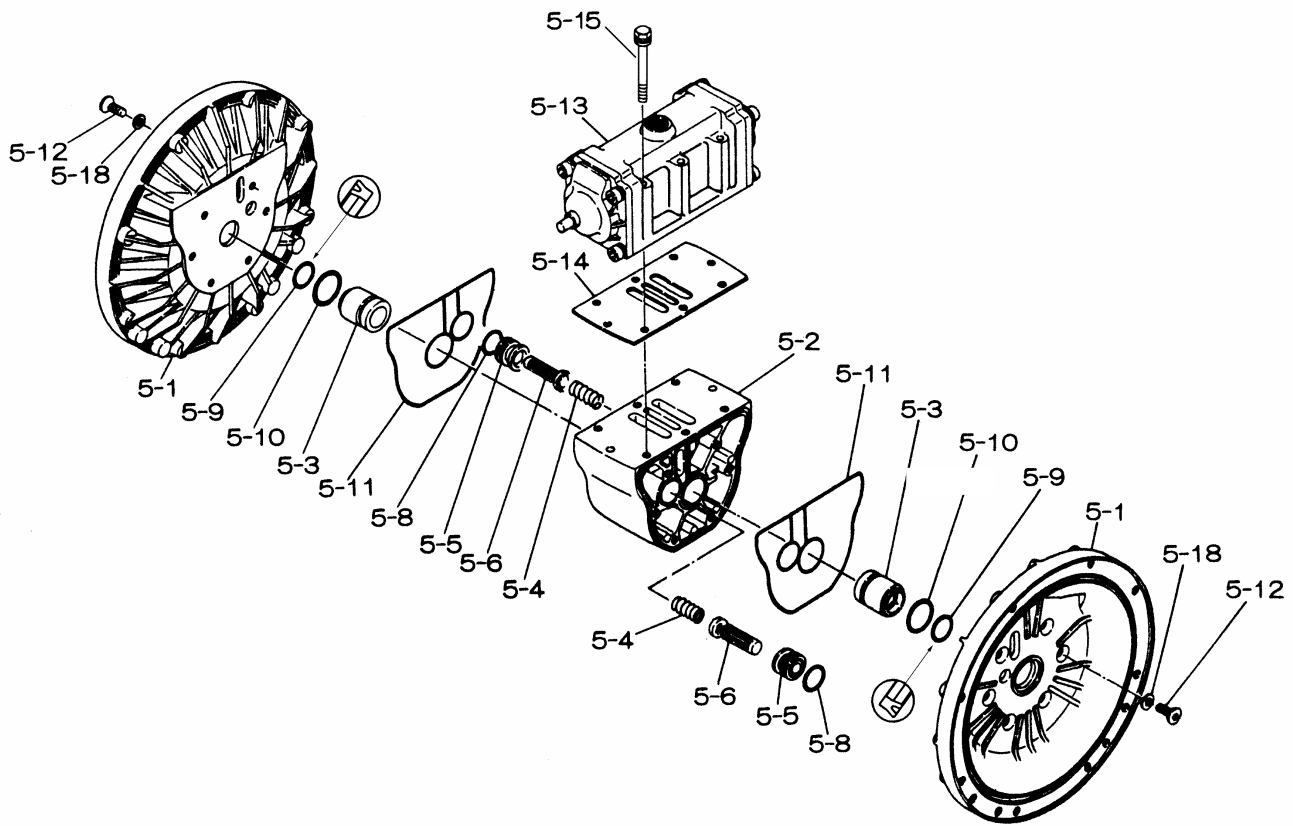

### 9.9 Parts List

### ■ BODY ASSEMBLY

#### BODY ASSEMBLY

| NO.  | NDP-40 |
|------|--------|
|      | 803111 |
|      | 803117 |
| 5-1  | 711933 |
| 5-2  | 711936 |
| 5-3  | 772689 |
| 5-4  | 711937 |
| 5-5  | 771740 |
| 5-6  | 832162 |
| 5-8  | 640020 |
| 5-9  | 685444 |
| 5-10 | 640029 |
| 5-11 | 771742 |
| 5-12 | 683812 |
| 5-13 | 802971 |
| 5-14 | 771712 |
| 5-15 | 684240 |
| 5-18 | 684987 |

| DESCRIPTION          | Q'TY | NOTE       |
|----------------------|------|------------|
| AIR CHAMBER          | 2    |            |
| BODY                 | 1    |            |
| THROAT BEARING       | 2    |            |
| SPRING               | 2    |            |
| VALVE SEAT           | 2    |            |
| PILOT VALVE ASSEMBLY | 2    |            |
| O RING               | 2    | P22A NBR   |
| PACKING              | 2    | PNY-25     |
| O RING               | 2    | P30 NBR    |
| GASKET               | 2    |            |
| FLAT HEAD BOLT       | 12   | M8x1.25x20 |
| VALVE BODY ASSEMBLY  | 1    |            |
| GASKET               | 1    |            |
| BOLT                 | 6    | M8x1.25x85 |
| PLAIN WASHER         | 12   |            |

### 9.10 Exploded View

### ■ VALVE BODY ASSEMBLY

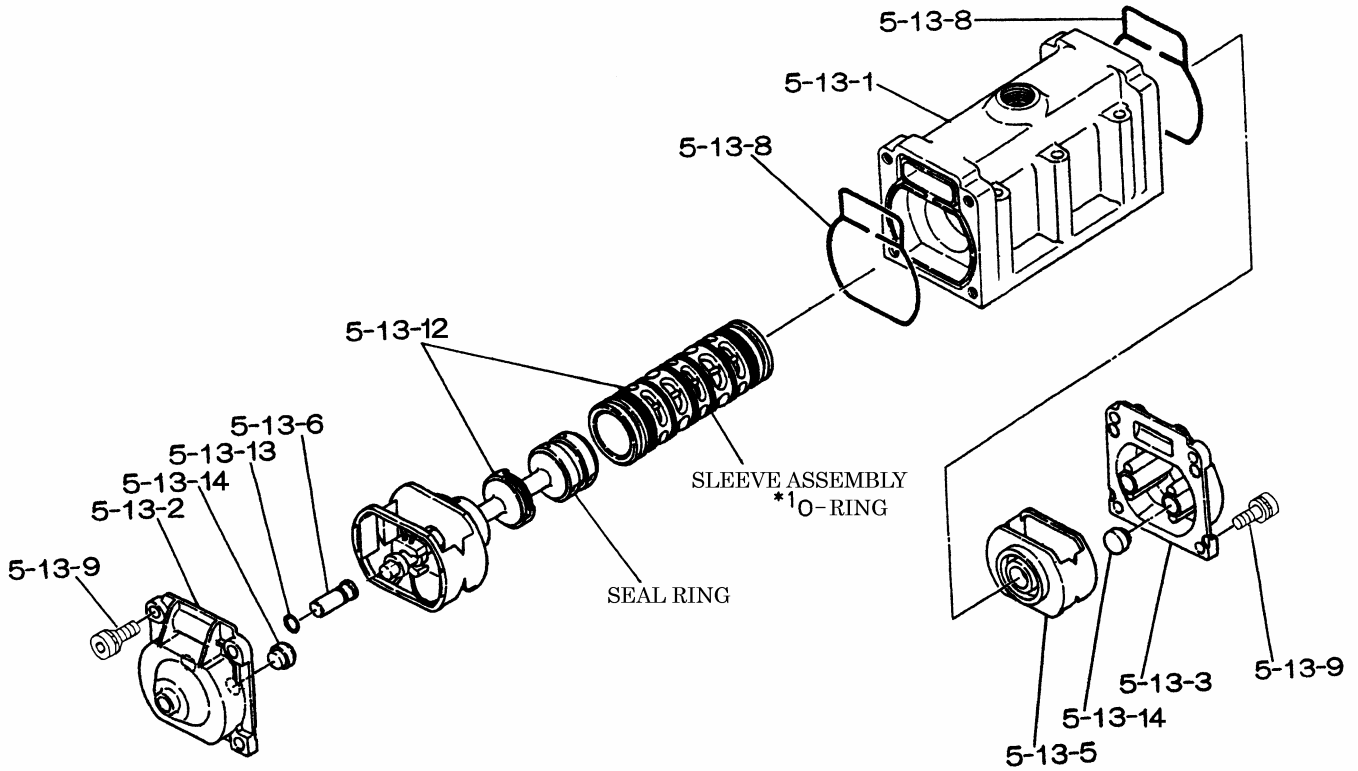

### 9.10 Parts List

### ■ VALVEBODY ASSEMBLY

#### 802971 VALVE BODY ASSEMBLY

| NO.     | PART NO. | DESCRIPTION              | Q'TY | NOTE       |
|---------|----------|--------------------------|------|------------|
| 5-13-1  | 711931   | VALVE BODY               | 1    |            |
| 5-13-2  | 580999   | CAP A                    | 1    |            |
| 5-13-3  | 581000   | CAP B                    | 1    |            |
| 5-13-5  | 771735   | SPRING STOPPER           | 1    |            |
| 5-13-6  | 712976   | RESET BUTTON             | 1    |            |
| 5-13-8  | 771738   | GASKET                   | 2    |            |
| 5-13-9  | 685036   | HEXAGON SOCKET HEAD BOLT | 8    | M8x1.25x20 |
| 5-13-12 | 803115   | C SPOOL VALVE ASSEMBLY   | 1    | *1(640036) |
| 5-13-13 | 640005   | O RING                   | 1    | P8 NBR     |
| 5-13-14 | 684128   | CUSHION                  | 4    |            |

NOTE)\*1:PARTS NUMBER MENTIONED ON O RING FOR SLEEVE ASSEMBLY ONLY.



## GENERAL TERMS OF SALE

### 1. GENERAL

A. Seller's price is based on these sales terms and conditions. The agreement and inclusion of other or amended terms in this contract will result in a change (including increase) in Seller's price (as may be contained in any price books or quotations) to reflect such other or amended terms. This contract shall represent the final, complete and exclusive statement of the agreement between the parties and may not be modified, supplemented, explained or waived by parole evidence, any Terms and Conditions contained in Buyer's purchase order or request for quotation, any course of dealings between the parties, Seller's performance or delivery, or in any other way. The Terms and Conditions of this contract may only be modified or waived in a written document signed by an Officer of Seller. These terms are intended to cover all activity of Seller and Buyer hereunder, including sales and use of products, parts and work and all related matters (references to products include parts and references to work include construction, installation and start-up). Any reference by Seller to Buyer's specifications and similar requirements are only to describe the products and work covered hereby and no warranties or other terms therein shall have any force of effect. Any information provided by Seller including, but not limited to, suggestions as to specific equipment does not imply any guarantee of specific suitability and/or material compatibility in a particular application, since many factors outside the control of Seller may affect the suitability of products in a particular application. Catalogs, circulars, similar pamphlets and information contained on websites of the Seller are issued for general information purposes only and shall not be deemed to modify the provisions hereof.

B. The agreement formed hereby and the language herein shall be construed and enforced under the Uniform Commercial Code as in effect in the State of California on the date hereof.

### 2. TAXES

Any sales, use or other similar type taxes imposed on this sale or on this transaction and/or any import or export duties or fees as may be assessed or imposed on or as a result of deliveries under this transaction are not included in the price. Such taxes shall be billed separately to the Buyer. Seller will accept a valid exemption certificate from the Buyer if applicable; however, if an exemption certificate previously accepted is not recognized by the governmental taxing authority involved and the Seller is required to pay the tax covered by such exemption certificate. Buyer agrees to promptly reimburse Seller for the taxes paid.

### 3. PERFORMANCE, INSPECTION AND ACCEPTANCE

A. Unless Seller specifically assumes installation, construction or start-up responsibility, all products shall be finally inspected and accepted within thirty (30) days after arrival at point of delivery. Where seller has responsibility for installation, construction or start-up all work shall be finally inspected and accepted within thirty (30) days after completion of the applicable work by Seller. All claims whatsoever by Buyer, (including claims for shortages) except only those provided for under the WARRANTY AND LIMITATION OF LIABILITY and PATENTS Clauses, hereof, must be asserted in writing by Buyer within said thirty (30) day period or they are waived. If this contract involves partial performance, all such claims must be asserted within said thirty- (30) day period for each partial performance. There shall be no revocation of acceptance. Rejection may be only for defects substantially impairing the value of products or work and Buyer's remedy for lesser defects shall be those provided for under the WARRANTY AND LIMITATION OF LIABILITY Clause.

B. Seller shall not be responsible for non-performance or for delays in performance occasioned by any causes beyond Seller's reasonable control, including, by way of example and not limitation, to labor difficulties, delays of vendors or carriers, fires, governmental actions, or shortages of material, components, labor, or manufacturing facilities. Any delays so occasioned shall affect a corresponding extension of Seller's performance dates, which are, in any event, understood to be approximate. IN NO EVENT SHALL BUYER BE ENTITLED TO INCIDENTAL OR CONSEQUENTIAL DAMAGES FOR LATE PERFORMANCE OR FOR A FAILURE TO PERFORM. Seller reserves the right to make partial shipments and to ship products, parts or work which may be completed prior to the scheduled performance date.

C. In the event that Seller has agreed to mount motors, turbines, gears, or other products which are not manufactured by Seller and which are not an integral part of Seller's manufactured product, and a delay in the delivery of such products to Seller occurs that will cause a delay in Seller's performance date, Seller reserves the right to ship its product upon completion of manufacture and to refund an equitable portion of the amount originally included in the purchase price for mounting without incurring liability for non-performance.

D. Seller reserves to itself the right to change its specifications, drawings and standards if such changes will not impair the performance of its products, and parts, and further those products, and parts, will meet any of Buyer's specifications and other specific product requirements which are a part of this agreement. Seller is a global supplier of products and utilizes parts and products obtained worldwide, and Seller's products supplied under this contract shall be subject to Seller's sole determination as to all manufacturing, sourcing, assembly and supply unless otherwise specifically agreed in writing.

E. The manufacture and inspection of products and parts shall be to Seller's Engineering and Quality Assurance standards, plus such other inspections or tests of documentation as are specifically agreed to by Seller. Requirements for any additional inspection, tests, documentation, or Buyer witness of manufacture, test, and/or inspection shall be subject to additional charges.

### 4. TITLE AND RISK OF LOSS

Title and risk of loss shall pass to buyer upon delivery of products at the designated "Ex Works" as defined by Incoterms, unless otherwise agreed by the parties.

### 5. EROSION AND CORROSION

It is specifically understood that products and parts sold hereunder are not warranted for operation with erosive or corrosive fluids or for operation with any fluid or under any operating condition in variance with the specifications of this contract. No product or part shall be deemed to be defective by reason of failure to resist erosive or corrosive action of any fluid and Buyer shall have no claim whatsoever against Seller therefore. No product shall be deemed defective by reason of any effect on Seller's products of the action or results (such as vibration) of any goods or system (such as piping) not supplied by Seller.

### 6. BUYER'S RESPONSIBILITY

The design specifications of the equipment require the operation of the equipment within certain parameters and may call for the use of speed controls, safety devices, set points or other control devices to insure that the operation remains within design parameters. Buyer agrees and understands that the equipment must be operated and maintained within design specifications and operated within the specifications of the contract, irrespective of whether controls or devices are otherwise required.

### 7. WARRANTY AND LIMITATION OF LIABILITY

A. Seller warrants only that its product and parts, when shipped, will be free from defects in materials and workmanship. All claims for defective products or parts under this warranty must be made in writing immediately upon discovery and, in any event, within two (2) years of shipment by seller and all claims for defective work must be made in writing immediately upon discovery. Defective items must be held for Seller's inspection and returned to the sellers' point of original shipment upon request.

ANY UNAUTHORIZED DISSASSEMBLY, ALTERATION OF OR TAMPERING WITH ANY PRODUCT OR COMPONENT MAY "VOID" THE WARRANTY, IN THAT SUCH ACTION WILL RESULT IN SELLER BEING RELEASED AND RELIEVED FROM ITS OBLIGATIONS UNDER THIS WARRANTY AND FOR ANY FURTHER COSTS OR ACTIONS UNDER CLAUSE 7.C, FOLLOWING, AND THE BUYER ASSUMING SOLE RESPONSIBILITY FOR THE COSTS AND RESULTS OF SUCH ACTION. THE FOREGOING IS EXPRESSLY IN LIEU OF ALL OTHER WARRANTIES WHATSOEVER, EXPRESS, IMPLIED AND STATUTORY, INCLUDING WITHOUT LIMITATION, THE IMPLIED, WARRANTIES OF MERCHANTABILITY AND FITNESS.

B. ANY PRODUCT (S) SOLD HEREUNDER WHICH ARE NOT MANUFACTURED BY SELLER ARE NOT WARRANTED BY SELLER and shall be covered only by the express warranty, if any, of the manufacturer thereof. With respect to products and parts not manufactured by Seller, Seller's only obligation shall be to assign to Buyer, to the extent possible, whatever warranty Seller obtains from the manufacturer.

C. Upon Buyer's submission of a claim as provided above and its substantiation, Seller shall at its option either (i) repair or replace its product, part or work at the original place of shipment, or (ii) refund an equitable portion of the purchase price.

D. THE FOREGOING IS SELLER'S ONLY OBLIGATION AND BUYER'S EXCLUSIVE REMEDY FOR BREACH OF WARRANTY AND, EXCEPT FOR THE REMEDIES PERMITTED UNDER THE PERFORMANCE, INSPECTION AND ACCEPTANCE AND THE PATENTS CLAUSES HEREOF, THE FOREGOING IS BUYER EXCLUSIVE REMEDY AGAINST SELLER FOR ALL CLAIMS ARISING HEREUNDER OR RELATING HERETO WHETHER SUCH CLAIMS ARE BASED ON BREACH OF CONTRACT, TORT (INCLUDING NEGLIGENCE OR STRICT LIABILITY), INDEMNITY OR OTHER THEORIES. BUYER'S FAILURE TO SUBMIT A CLAIM AS PROVIDED ABOVE SHALL SPECIFICALLY WAIVE ALL CLAIMS FOR DAMAGES OR OTHER RELIEF, INCLUDING BUT NOT LIMITED TO CLAIMS BASED ON LATENT DEFECTS. IN NO EVENT SHALL BUYER BE ENTITLED TO INDIRECT, SPECIAL, INCIDENTAL OR CONSEQUENTIAL DAMAGES, NOR FOR DAMAGES FOR LOSS OF USE, LOST PROFITS OR REVENUE, INTEREST, LOST GOODWILL, WORK OR PRODUCTION STOPPAGE, IMPAIRMENT OF OTHER GOODS, INCREASED EXPENSES OF OPERATION, OR THE COST OF PURCHASING REPLACEMENT POWER OR OTHER SERVICES BECAUSE OF SERVICE INTERRUPTIONS. FURTHERMORE, IN NO EVENT SHALL SELLER'S TOTAL LIABILITY FOR DAMAGES OF BUYER EXCEED THE PURCHASE PRICE OF THE PRODUCTS OR PARTS MANUFACTURED BY SELLER AND UPON WHICH SUCH LIABILITY IS BASED. ANY ACTION ARISING HEREUNDER RELATED HERETO, WHETHER BASED ON BREACH OF CONTRACT, TORT (INCLUDING NEGLIGENCE) OR OTHER THEORIES, MUST BE COMMENCED WITHIN ONE (1) YEAR AFTER THE CAUSE OF ACTION ACCRUES OR IT SHALL BE BARRED.

### 8. PURCHASER'S REPRESENTATIONS & WARRANTIES

Purchaser represents and warrants that the products(s) covered by this contract shall not be used in or in connection with a nuclear facility or application. The parties agree that this representation and warranty is material and is being relied on by seller. This provision may be modified in a separate writing signed by an officer of Price Pump Co.

### 9. PATENTS

Seller agrees to assume the defense of any suit for infringement of any patents brought against Buyer to the extent of such suit charges infringement of an apparatus or product claim by Seller's product in and of itself, provided (i) said product is built entirely to Seller's design, (ii) Buyer notifies Seller in writing of the filing of such suit within ten (10) days after the service of process thereof, and (iii) Seller is given complete control of the defense of such suit, including the right to defend, settle and make changes in the product for the purpose of avoiding infringement of any process or method claims. Provided however, Seller will not defend any suit for infringement of a claimed patent where such alleged infringement is the result of following specific instruction furnished by Seller.

### 10. EXTENT OF SUPPLY

Only products as listed in Seller's proposal are included in this agreement. It must not be assumed that Seller has included anything beyond same.

### 11. MANUFACTURING SOURCES

To maintain delivery schedules, Seller reserves the right to have all or any part of the Buyer's order manufactured at any of Sellers', sellers' licensees or sub contractors' plants, globally.

### 12. TERMS OF PAYMENT

Net 30 days from date of invoice.

### 13. ARBITRATION

In the event a dispute arises between the parties relating to or arising out of this agreement, the parties agree to attempt to have their senior management amicably settle the matter. In the event that the matter cannot be settled, the parties shall submit all disputes relating to this Agreement (whether contract, tort, products liability or otherwise) to binding Arbitration before a panel of arbitrators under the Commercial Dispute Resolution Procedures of the American Arbitration Association. Each party shall appoint an arbitrator and the third shall be selected in accordance with the rules of the American Arbitration Association. Judgment upon the award may be entered in any court having jurisdiction. The parties shall cooperate in providing reasonable disclosure of relevant documents. Each party shall bear its own expenses, and the costs and fees of the arbitration shall be borne as allocated by the Arbitrator.