



Price® Pump Co.

INSTALLATION, OPERATING AND MAINTENANCE MANUAL

TYPE CD CENTRIFUGAL PUMPS

MODELS: MS5050

PLEASE FILL IN FROM PUMP NAMEPLATE

Pump Model_____

Spec. No._____

Serial No._____

Price® Pump Company
21775 8th. Street East
Sonoma, CA 95476
Tel: 707-938-8441
Fax 707-938-0764
Email: sales@pricepump.com

RETAIN MANUAL FOR REFERENCE

Congratulations

You are now the owner of a Price® Pump Co. Centrifugal Pump. This pump was carefully inspected and subjected to final performance tests before being released for shipment. In order to achieve maximum performance and reliability, please follow the simple instructions in this manual.

RECOMMENDED PRECAUTIONS

1. For satisfactory operation and safety, maximum system pressure must not exceed 350 psi* (24.6kg/sq cm).
2. For satisfactory operation and safety, maximum fluid temperature must not exceed 300°F* (121°C).
3. No modifications, additions or deletions should be made to the pump without prior approval of the factory.
4. Drain pump completely and flush with water before servicing a pump handling volatile or harmful liquids.

READ CAREFULLY THE CAUTION BELOW

The performance of your Price® Pump Co. Centrifugal Pump is based on clean, room temperature, water with suction conditions as shown on the performance curves. If used to pump liquids other than water, pump performance may differ from rated performance based on the different specific gravity, temperature, viscosity, etc. of the liquid being pumped. A standard pump, however, may not be safe for pumping all types of liquids, such as toxic, volatile or chemical liquids, or liquids under extreme temperatures or pressures.

Please consult Price® Pump Co. technical specifications as well as local codes and general references to determine the appropriate pump for your particular application. Since it is impossible for us to anticipate every application of a Price® Centrifugal pump, if you plan to use the pump for a non-water application, contact Price® Pump Co. beforehand to determine whether such application may be appropriate and safe under the operating conditions. Failure to do so could result in property damage or personal harm.

* Depends on seal materials and seal type

Visit our website for product information and technical support

www.pricepump.com

INSTALLATION / OPERATING INSTRUCTIONS

CENTRIFUGAL PUMPS

Warning

Before installing, repairing or performing maintenance on this pump, read these instructions completely.

Disconnect power to pump before servicing to avoid dangerous or fatal electrical shock.

Match supply voltage and frequency to motor nameplate values. Incorrect voltage can cause fire or serious motor damage and void warranty.

Ground motor before connection to electrical power supply! Failure to ground motor can cause severe or fatal electrical shock!

Do not ground to gas supply line!

Before disassembling pump, be certain all liquid has been removed. If pump was used to pump hazardous or toxic fluid, it must be decontaminated prior to disassembly.

Close Coupled Motor Pumps

It is suggested that these pumps be firmly bolted to a level surface. Adequate air movement around motor will help prevent overheating.

Do not over tighten inlet and outlet piping or volute may be damaged.

Power Frame Mounted Pumps

Power Frame mounted pumps must be mounted on a rigid base that will not warp or flex. Each pump must be mounted such that the pump shaft centerline is in-line with the driver shaft centerline. Pads and/or shims will be required on the pump, the driver or both to insure proper alignment. The two shafts should not touch each other (end to end) and the distance between them depends on the coupling used to connect them.

Misalignment will cause vibration, bearing failure and void warranty. Pumps are rough aligned at the factory

but must be realigned after shipment and installation.

Pulley driven pump must have pulleys inline and proper belt tightness practices followed.

Direction of Rotation

Note: Motor shaft rotation is viewed from the suction end of pump. A rotational arrow is shown on the front of the pump volute casing. Incorrect rotation can cause pump damage, failure or reduced performance, voiding warranty. It is best to check rotation by momentarily energizing or jogging the motor prior to filling pump with liquid.

Warning! Do not operate pump without liquid as damage may result to the pump internal wear surfaces.

Plumbing

All piping needs to be supported independently of the pump. Piping connections should not exert any stress on the pump volute or fittings.

INSTALLATION / OPERATING INSTRUCTIONS

Suction Piping (Inlet)

(Horizontal Pumps)

Suction line must provide adequate suction pressure and even (Laminar) liquid flow for proper pump operation. Air, entrapped in the suction line due to leaks or improper piping design, may cause the pump to lose prime. Non-priming pumps must have their suction 'flooded' at start up (see datasheets for minimum NPSHR). Also, the suction line must provide sufficient pressure (NPSH) and even flow to pump inlet to prevent pump cavitation. The suction pipe entering the pump should be straight and a minimum length of 5 times and preferably 10 times the pump inlet diameter. Elbows, fittings or valves installed close to the pump inlet can disrupt liquid flow and cause cavitation. Suction lines must be at least the same diameter as the pump inlet or larger if possible.

Price Pump Company recommends against using foot valves in the suction line to maintain liquid in the pump when it's not operating. If foot valves are used, due to suction lift conditions, they must be properly maintained to avoid

leaks resulting from wear or fouling. Suction piping must be designed to prevent vapor from being trapped in high spots in the piping. This condition may cause the pump to vapor lock.

Discharge Piping (Outlet)

To control flow and discharge head, it is advisable to install a valve (globe, ball, or other adjustable and non-leak type) in the discharge line adjacent to the pump. The valve may be closed during system repairs to prevent backflow. By installing a check valve in the discharge line, backflow can also be prevented during maintenance or during periods of pump stoppage.

Operation

All centrifugal pumps must be filled with liquid prior to start up. It is suggested that during initial start up the discharge valve be closed and then opened as the motor reaches full rpm's. If pump does not build up pressure as motor speed increases, shut down and make sure that liquid flow into pump is not restricted (see "Troubleshooting").

Note: A centrifugal pumps flow rate and head (pressure) will vary with the amount of resistance (pipe friction and flow restrictions) in the discharge line. As the valve on the discharge line opens, the flow rate and motor amperes draw will increase and head (pressure) will decrease. As the valve on the discharge line is closed, the flow rate and amperes draw will decrease and the head (pressure) will increase.

If resistance in the discharge line is not sufficient, the pump will operate at a condition of maximum flow, sometimes called "end of curve" performance. Maximum horse-power is required to operate at this point and motor overload may result. If excessive amperes draw and motor overload is occurring, reduce the system flow rate by installing a valve or orifice in the discharge line to control (restrict) the pumps flow rate. Alternatively, reduce pump head by trimming impeller to a smaller diameter.

Consult Price Pump or a local Price Pump distributor for assistance.

www.appsupport@pricepump.com

TROUBLESHOOTING

1. Pump fails to build head pressure:

Check for:

- a. Pump not primed.
- b. Incorrect pump rotation.
- c. Driver speed too low.
- d. Suction line restricted.
- e. Driver failure.
- f. Plugged or damaged impeller.
- g. Pump or impeller undersized.
- h. Pump cavitation.
- i. Improper impeller clearance.

2. Pump fails to provide enough flow rate.

Check for:

- a. System resistance too high.
- b. Pump undersized.
- c. Pump not primed.
- d. Driver speed too low.
- e. Poor suction conditions.
- f. Improper impeller clearance.

3. Excessive noise or vibration during operation.

Check for:

- a. Motor bearing failing.
- b. Pump cavitation.
- c. Improper impeller clearance.

4. Leaking mechanical seal.

Check for:

- a. Improper assembly.
- b. Worn or cracked seal faces.
- c. Abrasive material in fluid.
- d. Liquid flashing at seal faces (Fluid temperature too high).
- e. Seal pressure rating too low for the service.
- f. Chemical attack of seal components.
- g. Seal operated dry or with a liquid having poor lubricating properties.

5. Pump gradually loses pressure and head.

Check for:

- a. Increasing temperature causing cavitation or liquid vaporization.
- b. Driver failure.
- c. Suction lift too high.
- d. Air entering suction line.

6. Motor overheating.

Check for:

- a. Excessive flow and amp draw (Throttle discharge).
- b. Low voltage or frequency.
- c. Flow rate too low with resulting heat rise.
- d. Bearing failure.
- e. System temperature too high.

REPAIR AND MAINTENANCE

Before attempting any repairs under warranty, contact Price Pump to obtain factory authorization.

Repairs carried out without authorization may void warranty. Many causes of pump failure are due to improper system design. Refer to the trouble shooting list in this manual before carrying out pump inspection or repair.

DISASSEMBLY

1. Disconnect power source to motor.
2. Disconnect electrical connections tagging wires carefully to preserve correct rotation. Loosen motor base.
3. Remove pump and motor assembly. Observe position of all parts prior to disassembly.
4. Remove stage connector bolts.
5. Remove suction plate.
6. Loosen impeller setscrews and remove impeller by sliding off pump shaft.
7. Slide diffuser off of pump shaft.
8. Remove stage separator and O-ring.
9. Repeat steps 5 through 7 until last impeller is removed from the pump shaft.
10. Remove seal head from pump. Type 21: Slide seal head from the shaft. Type 9: Loosen set screws and slide seal head off shaft.
11. Remove four motor bolts and remove bracket from motor.

12. Remove seal seat from bracket. Use wooden or plastic dowel to tamp the seat from the bracket.

REASSEMBLY

1. Clean seat cavity of the bracket thoroughly.
2. Thoroughly clean pump shaft. Assure that the shaft is not grooved and that there is no evidence of pitting or fretting. Polish the shaft with extra fine emery cloth and clean the keyway. If the shaft is grooved, fretted or worn, replace it.
3. Install the pump shaft onto the motor shaft, aligning set screws of the pump shaft with the keyway of the motor shaft. Ensure all debris and burrs are removed from the motor shaft and that the slinger is in place, midway between the setscrews.
4. For Type 21, 8, 9 seals: Place the bracket on a firm surface with the seat cavity (pump end) up. Then place a small amount of vegetable oil on the seat cup or "O" ring seat. Place the seat in the seat cavity with the polished face up toward the pump end. Evenly push seat into cavity with fingers.

To help ensure the seat is not damaged place the cardboard disk supplied with the seal over the seat face. Gently tap seat into place with a wooden dowel or a plastic rod (1-1/8" outside diameter).

5. Place bracket on motor (aligning the base if applicable). Secure bracket with four motor bolts.
6. Pull pump shaft forward until shoulder of pump shaft contacts back of bracket and slightly snug one setscrew to hold shaft in place.

7. Install seal head assembly

For Type 21 Seals:

- a. Lubricate shaft and elastomer with vegetable oil.
- b. Install rotary seal head onto pump shaft and slide toward seat until carbon face touches ceramic seat.
- c. Install seal spring and retainer.
- d. Install impeller. Slide impeller onto shaft until impeller hub bottoms out on the shoulder of the shaft. Tighten impeller setscrews securely.

REPAIR AND MAINTENANCE

REASSEMBLY (cont.)

Note: Ensure that the spring retainer does not slip between the shoulder of the shaft and the hub of the impeller.

e. Install new volute O-ring and mount volute (lightly coat O-ring with vegetable oil). Secure with bolts and tighten.

f. Loosen pump shaft setscrew and install stage separator with chamfer side towards impeller. Push stage separator until it bottoms out on the flange.

Note: For 1 stage pumps there is no stage separator. Install the suction plate and set impeller.

g. While pressure is applied to stage separator slightly snug one pump shaft setscrew at this time to hold the pump shaft in place.

h. Install O-ring on diffuser and lightly coat O-ring with vegetable oil. Install diffuser with O-ring onto the volute case. When installing diffuser apply even pressure to avoid damaging carbon bushing.

i. Install next stage impeller; do not tighten impeller setscrews at this time.

j. Install setting plate and tighten bolts.

k. Pull impeller forward with setscrew wrench provided in assembly kit until impeller touches the setting plate. Tighten impeller setscrews.

l. Remove setting plate. Install next stage separator and diffuser with O-ring.

m. Install the next stage impeller; do not tighten impeller setscrews at this time.

n. Install setting plate and tighten bolts.

o. Pull impeller forward with setscrew wrench provided in assembly kit until impeller touches the setting plate. Tighten impeller setscrews.

p. Remove setting plate and repeat steps l. through o. for additional stages.

q. After last impeller is set, remove setting plate and install suction plate and tighten bolts.

8. Set impeller clearance with setting tool. Turn setting tool approximately 1/2-3/4 of a turn. Proceed to step 10.

For Type 8 & 9 Seals:

a. Install impeller. Slide impeller onto shaft until impeller hub bottoms out on the shoulder of the shaft. Snug impeller setscrews.

b. Install new volute O-ring and mount volute (lightly coat O-ring with vegetable oil). Secure with bolts and tighten.

c. Loosen pump shaft setscrew and install stage separator with chamfer side towards impeller. Push stage separator until it bottoms out on the flange.

Note: For 1 stage pumps there is no stage separator. Install the setting plate and set impeller.

d. While pressure is applied to stage separator slightly snug one pump shaft setscrew at this time to hold the pump shaft in place.

e. Remove stage separator and impeller. Install seal.

Install Seal: Type -9

f. Do not remove metal clips from seal head. Install seal head onto pump shaft sliding gently past shoulder of shaft. Slide seal head toward seat until carbon face contacts ceramic seat. Tighten seal head setscrews to pump shaft using short arm Allen wrench supplied with seal or repair kit. Remove clips in seal head and discard.

REPAIR AND MAINTENANCE

REASSEMBLY (cont.)

Type-8

Compress seal to a distance of 3/4" from, the front side of seat face, to the backside of seal casing. (do not measure from bore face of bracket). Tighten seal head set screws

g. Reinstall impeller (tighten setscrews securely).

h. Reinstall stage separator.

i. Install O-ring on diffuser and lightly coat O-ring with vegetable oil. Install diffuser with O-ring onto the volute case. When installing diffuser apply even pressure to avoid damaging carbon bushing.

j. Install next stage impeller, do not tighten impeller setscrews at this time.

k. Install setting plate and tighten bolts.

l. Pull impeller forward with setscrew wrench provided in assembly kit until impeller touches the setting plate. Tighten impeller sets crews.

m. Remove setting plate. Install next stage separator and diffuser with O-ring.

n. Install next stage impeller; do not tighten impeller setscrews at this time.

o. Install setting plate and tighten bolts.

p. Pull impeller forward with setscrew wrench provided in assembly kit until impeller touches the setting plate. Tighten impeller setscrews.

q. Remove setting plate and repeat steps m. through p. for additional stages.

r. After last impeller is set, remove setting plate and install suction plate and tighten bolts.

9. Set impeller clearance with setting tool. Turn setting tool approximately 1/2-3/4 of a turn. Proceed to step 10.

10. Rotate pump shaft by hand to ensure impeller does not rub against volute.

11. Return pump to installation, reconnect electric connections.

12. Start pump momentarily to observe shaft rotation. If rotation corresponds the rotation arrow pump may be put into service. If rotation is incorrect, switch any two leads on 3-phase motors. Check wiring diagram of motor for single phase rotation.

13. Remove top pipe plug (if applicable) from the front of volute and prime pump

thoroughly, making sure all air is purged.

14. Start pump allowing adequate time to purge all air from system. Observe any gauges, flow meters, e tc. to see of pump performs properly.

REPAIR AND MAINTENANCE

INSTALLING A PEO (PUMP END ONLY) STUB SHAFT PUMP

- a. Place the bracket on a firm surface, loosen stub shaft setscrews and carefully remove shipping plug.
- b. Place motor in an upright position with motor shaft pointing upward. Make sure motor shaft and end bell flange are free of burrs and surfaces are clean.
- c. Align PEO stub shaft setscrews (if applicable) with motor shaft keyway and carefully slid the PEO onto the motor shaft until it sits firmly onto the motor end bell flange.
- d. Oriented the PEO's discharge port or base to preferred motor configuration while referencing the motors electrical box position.
- e. Install flange bolts and tighten. (Install pump base if applicable)
- f. Reposition pump back onto motor base.
- g. Refer to pump Reassembly Instructions and proceed to **setting the impeller clearance** (if applicable).

INSTALLING A PEO (PUMP END ONLY) NON-STUB SHAFT PUMP

- a. Carefully un-pack all components received with your shipment and remove any shipping plugs.
- b. Place the bracket on a firm surface with the seat cavity (pump end) up. Follow seal Installation / reassembly instructions contained within this manual.
- c. Make sure motor shaft and motor end bell flange are free of burrs and surfaces are clean.
- d. Carefully place the Bracket assembly over the motor shaft and align bracket with motor end bell flange.
- e. Install impeller, gasket or o-ring, volute and volute mounting bolts.
- f. Oriented the PEO's discharge port or base to preferred motor configuration while referencing the motors electrical box position.
- g. Install motor flange bolts and tighten all bolts to proper torque. (Install pump base if applicable)

REPAIR AND MAINTENANCE

Type 21 C Face Style Double Seal Installation

(For Type CD, RC, LT & MS Series Pumps)

Double Seal pumps are generally used for one of these reasons:

1. To avoid seal damage when pumping abrasives.
2. To manage seal temperature when pumping hot liquids.
3. To prevent pump fluid from leaking to atmosphere when pumping toxic or other hazardous liquids.

A double seal must have pressure to the seal chamber at a minimum of 5 PSI preferable 10 PSI above pump pressure.

Flow rate through seal chamber will depend upon pump fluid temperature. Minimum flow rate should be **1 GPM** for CD, RC, LT & MS Series Pumps . Flow rates may have to be increased with higher temperatures. Check the seal chamber discharge fluid temperature to be sure fluid is below boiling . We suggest a 140°F to 150°F temperature range. If seal cooling liquid flashes, seal may become damaged. Seal chamber fluid should enter at the bottom and discharge at the top to avoid entrapped air in the chamber. Be sure to prime the secondary pumping system properly as you would any other system.

CAUTION: Always Pressurize the Seal Chamber before starting the main pump!

In a pumping system that starts and stops automatically, insure that both pumps start at the same time.

REASSEMBLY:

- | | | |
|---|---|---|
| 1. Clean seat cavity of the bracket and seal plate thoroughly. | of the motor shaft. Ensure all debris and burrs are removed from the motor shaft and that the slinger is in place. | on the seat cup. Install seats into seat plate and bracket with polished faces up. Evenly push seat into seat cavity with fingers, then gently tap seat into place with a wooden dowel or plastic rod (1 -1/8" outside diameter). To help ensure the seat is not damaged, place the cardboard disk supplied with the seal under the end of the dowel to prevent damaging the seat face. |
| 2. Thoroughly clean pump shaft. Assure that the shaft is not grooved and that there is no evidence of pitting or fretting. Polish the shaft with extra fine emery cloth and clean the keyway. If the shaft is grooved, fretted or worn, replace it. | 4. Place bracket on motor (aligning the base if applicable). Secure bracket with four motor bolts. | |
| 3. Install the pump shaft onto the motor shaft, aligning set screws of the pump shaft with the keyway | 5. Pull out pump shaft as far as it will go toward volute end and slightly tighten one set screw to hold shaft in place | 7. Install seal head assembly: |
| | 6. Place a small amount of vegetable oil (or equivalent) | |

REPAIR AND MAINTENANCE

For Type 21:

a. Lubricate shaft and elastomer with vegetable oil or equivalent.

b. Install first rotary seal head onto pump shaft and slide toward seat using a twisting motion until carbon face touches seal seat.

c. Install second rotary seal head onto shaft sleeve with carbon facing towards pump end.

8. Install seal plate onto pump end of bracket with new gasket and tighten cap screws evenly (note: use pipe sealant on bolts).

9. Install impeller:

a. Install key in pump shaft.

b. Slide impeller onto shaft.

c. Install impeller washer and lockdown. Tighten to 10 ft-lbs.

10. Loosen pump shaft set screw.

11. Install new volute gasket or o-ring and mount volute. Secure with bolts and tighten evenly.

12. Move shaft back with a screwdriver **.010"-.015"**. Tighten pump shaft set screws. Turn shaft by hand to ensure impeller does not rub against volute.

13. Return pump to installation, reconnect electric connections.

14. Start pump momentarily to observe shaft rotation. If rotation corresponds to the

rotation arrow on the pump, it may be put into service. If rotation is incorrect, switch any two leads on 3-phase motors to change rotation. Check wiring diagram of motor for single phase rotation correction.

15. Remove top pipe plug (if applicable) from the front of volute and prime pump thoroughly, making sure all air is purged. Turn shaft one revolution and then refill. Replace the pipe plug.

16. Start pump allowing adequate time to purge all air from system. Observe any gauges, flow meters, etc., to see if pump performs properly.

Double Seal Flush Piping Installation

1. Piping of the double seal arrangement should be done in accordance with all governmental regulations and safety codes.

2. All double seals require a barrier flush between the seals for proper lubrication and cooling. The barrier liquid must be maintained at 10-15 PSIG above the discharge pressure of the pump and it must be chemically compatible with the pumped liquid, material construction of the pump,

and seals (5/8" double seals have 18-8 parts).

3. The barrier flush shall have a minimum flow rate in accordance with the graph below. If water is used as a fluid, the inlet temperature should not exceed 140°F.

4. A positive pressure must be maintained to the barrier flush between the seal faces even when the pump is not running. To conserve the barrier liquid a solenoid

valve (Item 1) may be installed and connected electrically in parallel with the motor so the barrier fluid flows only when the pump is running. Note: The maximum pressure of the barrier fluid at the inlet is 150 PSIG.

5. The inlet should be connected to the bottom and the outlet to the top of the seal cavity.

REPAIR AND MAINTENANCE

Procedures for Checking Double Seals for Internal Leakage

Option 1 - for use with 2 flow meters.

Install flow meters on the inlet and outlet lines. Normal operating conditions will be indicated by equal or near equal flow on both flow meters. If the inlet flow meter shows more flow than the outlet, this could indicate excessive leakage.

Option 2 - for use with 1 flow meter.

1. Shut off flow at outlet needle valve (Item 2).
2. Shut off inlet gate valve (Item 8) - for 15 seconds maximum.
3. If pressure in seal cavity drops rapidly rather than gradually while the gate valve is shut, the seal is leaking excessively.
4. To restart open gate valve first then reset valve on outlet.

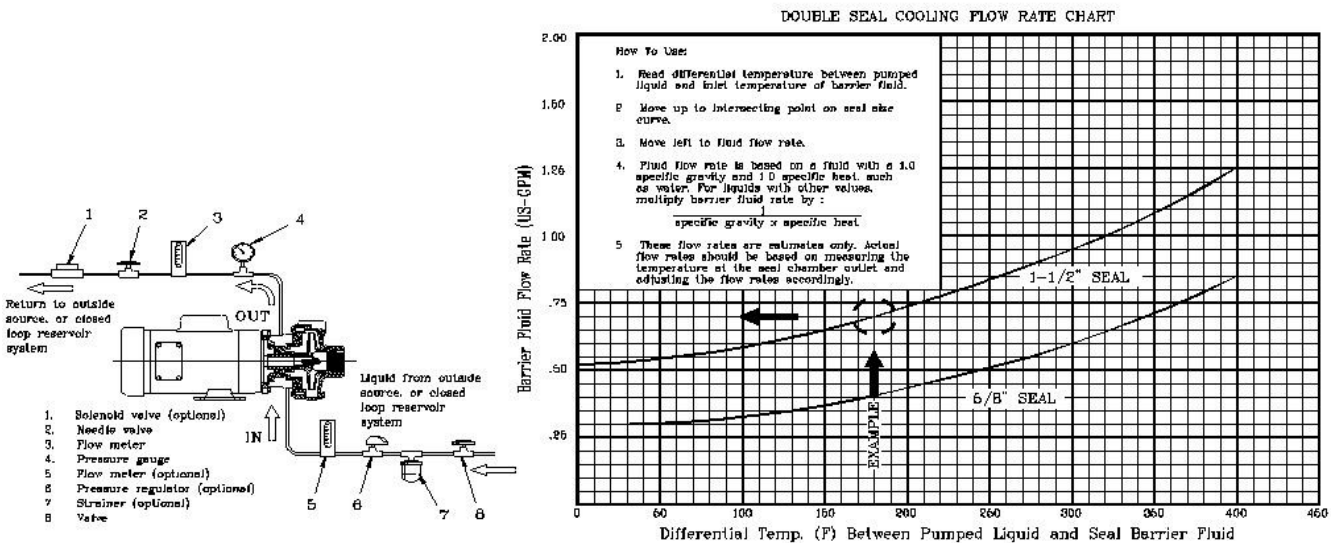

ART-010

THIS PAGE INTENTIONALLY LEFT BLANK



PRICE PUMP CO.

MS50 SS Parts List

MSS0 plist.doc rev. B

Key #	Description	Qty.	Number of Stages						
			1MS	2MS	3MS	4MS	5MS	6MS	
A.	Suction Plate		3010	3010	3010	3010	3010	3010	3010
B.	Impeller(s)	(1 req'd. per stage)	3040-4.12	3040-4.12	3040-4.12	3040-4.12	3040-4.12	3040-4.12	3040-4.12
	Setscrews	(2 req'd. per stage)	3080	3080	3080	3080	3080	3080	3080
C.	O Rings (Diffuser/Volute)								
	Fluorocarbon (1 + # of stages req'd.)		3070	3070	3070	3070	3070	3070	3070
	PTFE (1 + # of stages req'd.)		3071	3071	3071	3071	3071	3071	3071
	Neoprene (1 + # of stages req'd.)		3072	3072	3072	3072	3072	3072	3072
	EPR (1 + # of stages req'd.)		3073	3073	3073	3073	3073	3073	3073
D.	Diffuser	(1 - # of stages req'd.)	N/A	3020-1	3020-1	3020-1	3020-1	3020-1	3020-1
E.	Bushing(s):								
	Graphite (1 - # of stages req'd.)		N/A	3075	3075	3075	3075	3075	3075
	GFT (1 - # of stages req'd.)		N/A	3076	3076	3076	3076	3076	3076
F.	Volute		3000	3000	3000	3000	3000	3000	3000



PRICE PUMP CO.

MS50 SS Parts List

MSS0 plist.doc rev. B

Key #	Description	Qty.	1MS	2MS	Number of Stages			6MS
					3MS	4MS	5MS	
G.	Volute Bolts (8 req'd.)		0917	0917	0917	0917	0917	0917
J.	Shaft w/setscrews:							
	5/8" ID		3050-1	3055-1	3060-1	3065-1	3066-1	3067-1
	7/8" ID		3132-1	3133-1	3134-1	3135-1	3136-1	3137-1
K.	Slinger, 7/8"		0522	0522	0522	0522	0522	0522
L.	Motor Bolts (2 of ea. req'd.)		0673 / 0593	0673 / 0593	0673 / 0593	0673 / 0593	0673 / 0593	0673 / 0593
M1.	Motor		Specify P/N					
M2.	Power Frame 5/8" ID Shaft		5478	5478	5478	5478	5478	5478
	Power Frame 7/8" ID Shaft		5501	5501	5501	5501	5501	5501
M3.	Air Motor		Specify P/N					
N.	Stage Bolts (4 req'd.)		3083	3084	3085	3086	3087	3088
P.	Stage Nuts (4 req'd.)		3082	3082	3082	3082	3082	3082
Q.	Washers (4 req'd.)		3081	3081	3081	3081	3081	3081
R.	Base		0199	0199	0199	0199	0199	0199



PRICE PUMP CO.

MS50 plist.doc rev. B

MS50 SS Parts List

Key #	Description	Qty.	Number of Stages						
			1MS	2MS	3MS	4MS	5MS	6MS	
S.	Bracket		0972	0972	0972	0972	0972	0972	0972
T.	Stage separator(s):								
	Single Seal (1 - # of stages req'd.)		N/A	3030	3030	3030	3030	3030	3030
	Double Seal		N/A	3030-1(1 req'd.)	3030(1 req'd.)	3030(2 req'd.)	3030(3 req'd.)	3030(4 req'd.)	
	Suction Plate for Dbl Seal		3010-1	N/A	N/A	N/A	N/A	N/A	N/A
	Seal w/Seat:								
U1.	T.21 Fluorocarbon Single Seal		0553	0553	0553	0553	0553	0553	0553
U2.	T.21 Fluorocarbon Dbl Seal (2 req'd.)		0985	0985	0985	0985	0985	0985	0985
U3.	T.9 PTFE Single Seal		1150	1150	1150	1150	1150	1150	1150
W.	Double Seal Cover		0973	0973	0973	0973	0973	0973	0973
V.	Seal Cover Gasket		0974	0974	0974	0974	0974	0974	0974
X.	Seal Cover Bolts (3 req'd.)		0256	0256	0256	0256	0256	0256	0256
Y.	Quench Lip Seal Fluorocarbon		0891	0891	0891	0891	0891	0891	0891



PRICE PUMP CO.

MS50_P.dwg rev. A

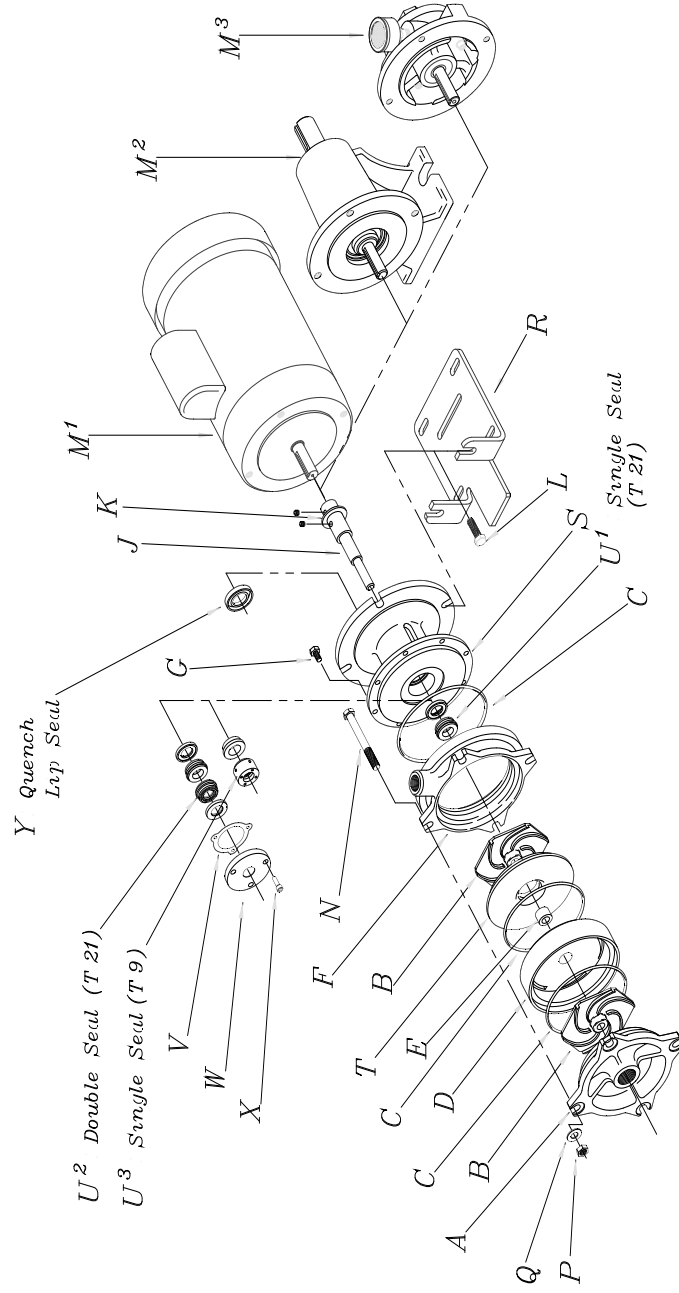

MS5 .

Price Pump Co.

21775 Eighth Street East * Sonoma, CA 95476-0329 * (707) 938-8441 * Fax (707) 938-0764

PRICE CENTRIFUGAL PUMP CAUTIONS & WARNINGS

- **CAUTION:** Price Pump centrifugal pumps must be operated above minimum flow rate to avoid damage .
- **CAUTION:** All Price Pump centrifugal pumps require the suction to be flooded .
- **CAUTION:** It is recommended that all piping connections to the pump be flexible.
- **WARNING:** Verify chemical compatibility of the pump materials of construction with the fluid being pumped.
- **WARNING:** Price centrifugal pumps are not designed for use in sanitary or food applications.
- **CAUTION:** Use only Price Pump original equipment factory replacement parts.
- **WARNING:** Price pump fluid temperature limits must be observed. Maximum operating temperature is 300 °F.
- **CAUTION:** The pump should be thoroughly flushed and drained before disassembly.
- **CAUTION:** For larger pump motor units, weight may exceed 65 lbs. (30 kg).

CAUTION: Maximum working pressure for seals:

- | | |
|------------------|---------------------------|
| ○ Type 6 Seal | 75 PSI (5.2 bar) |
| ○ Type 6A Seal | 75 PSI (5.2 bar) |
| ○ Type 8 Seal | 325 PSI (22.4 bar) |
| ○ Type 9 Seal | 350 PSI (24.1 bar) |
| ○ Type 21 Seal | 150 PSI (10.3 bar) |
| ○ Type 2106 Seal | 150 PSI (10.3 bar) |

CAUTION: Maximum solid size by pump

- | | |
|---------------|------------------------|
| ○ HP75 / MS50 | 0.030" (0.76mm) |
| ○ SP150 | 0.060" (1.50mm) |
| ○ LT25 | 0.120" (3.05mm) |
| ○ F50/75/95 | 0.150" (3.81mm) |
| ○ OH75 | 0.150" (3.81mm) |
| ○ CD100/150 | 0.150" (3.81mm) |
| ○ CL150 | 0.150" (3.81mm) |
| ○ RC200/300 | 0.380" (9.60mm) |
| ○ XJ-JB100 | 0.120" (3.05mm) |
| ○ XJ-JB150 | 0.250" (6.40mm) |
| ○ XJ-JB200 | 0.440" (11.2mm) |
| ○ XJ400 | 0.440" (11.2mm) |
| ○ XL-XT100 | 0.120" (3.05mm) |
| ○ XL-XT150 | 0.250" (6.40mm) |
| ○ XL-XT200 | 0.440" (11.2mm) |

CAUTION: Minimum flow rate by pump

- | | |
|---------------|--------------------------|
| ○ HP75 / MS50 | 0.5 GPM (1.9 LPM) |
| ○ SP150 | 10 GPM (38 LPM) |
| ○ LT25 | 0.5 GPM (1.9 LPM) |
| ○ F50/75/95 | 5.0 GPM (19 LPM) |
| ○ OH75 | 7.0 GPM (26 LPM) |
| ○ CD100 | 12 GPM (45 LPM) |
| ○ CD150 | 25 GPM (94 LPM) |
| ○ CL150 | 40 GPM (150 LPM) |
| ○ RC200 | 10 GPM (38 LPM) |
| ○ RC300 | 50 GPM (189 LPM) |
| ○ XJ-JB150 | 20 GPM (75 LPM) |
| ○ XJ-JB150 | 40 GPM (150 LPM) |
| ○ XJ-JB200 | 90 GPM (340 LPM) |
| ○ XJ400 | 100 GPM (378 LPM) |
| ○ XL-XT100 | 10 GPM (38 LPM) |
| ○ XL-XT150 | 35 GPM (132 LPM) |
| ○ XL-XT200 | 50 GPM (189 LPM) |



GENERAL TERMS OF SALE

1. GENERAL

A. Seller's price is based on these sales terms and conditions. The agreement and inclusion of other or amended terms in this contract will result in a change (including increase) in Seller's price (as may be contained in any price books or quotations) to reflect such other or amended terms. This contract shall represent the final, complete and exclusive statement of the agreement between the parties and may not be modified, supplemented, explained or waived by parole evidence, any Terms and Conditions contained in Buyer's purchase order or request for quotation, any course of dealings between the parties, Seller's performance or delivery, or in any other way. The Terms and Conditions of this contract may only be modified or waived in a written document signed by an Officer of Seller. These terms are intended to cover all activity of Seller and Buyer hereunder, including sales and use of products, parts and work and all related matters (references to products include parts and references to work include construction, installation and start-up). Any reference by Seller to Buyer's specifications and similar requirements are only to describe the products and work covered hereby and no warranties or other terms therein shall have any force of effect. Any information provided by Seller including, but not limited to, suggestions as to specific equipment does not imply any guarantee of specific suitability and/or material compatibility in a particular application, since many factors outside the control of Seller may affect the suitability of products in a particular application. Catalogs, circulars, similar pamphlets and information contained on websites of the Seller are issued for general information purposes only and shall not be deemed to modify the provisions hereof.

B. The agreement formed hereby and the language herein shall be construed and enforced under the Uniform Commercial Code as in effect in the State of California on the date hereof.

2. TAXES

Any sales, use or other similar type taxes imposed on this sale or on this transaction and/or any import or export duties or fees as may be assessed or imposed on or as a result of deliveries under this transaction are not included in the price. Such taxes shall be billed separately to the Buyer. Seller will accept a valid exemption certificate from the Buyer if applicable; however, if an exemption certificate previously accepted is not recognized by the governmental taxing authority involved and the Seller is required to pay the tax covered by such exemption certificate. Buyer agrees to promptly reimburse Seller for the taxes paid.

3. PERFORMANCE, INSPECTION AND ACCEPTANCE

A. Unless Seller specifically assumes installation, construction or start-up responsibility, all products shall be finally inspected and accepted within thirty (30) days after arrival at point of delivery. Where seller has responsibility for installation, construction or start-up all work shall be finally inspected and accepted within thirty (30) days after completion of the applicable work by Seller. All claims whatsoever by Buyer, (including claims for shortages) except only those provided for under the WARRANTY AND LIMITATION OF LIABILITY and PATENTS Clauses, hereof, must be asserted in writing by Buyer within said thirty (30) day period or they are waived. If this contract involves partial performance, all such claims must be asserted within said thirty- (30) day period for each partial performance. There shall be no revocation of acceptance. Rejection may be only for defects substantially impairing the value of products or work and Buyer's remedy for lesser defects shall be those provided for under the WARRANTY AND LIMITATION OF LIABILITY Clause.

B. Seller shall not be responsible for non-performance or for delays in performance occasioned by any causes beyond Seller's reasonable control, including, by way of example and not limitation, to labor difficulties, delays of vendors or carriers, fires, governmental actions, or shortages of material, components, labor, or manufacturing facilities. Any delays so occasioned shall affect a corresponding extension of Seller's performance dates, which are, in any event, understood to be approximate. IN NO EVENT SHALL BUYER BE ENTITLED TO INCIDENTAL OR CONSEQUENTIAL DAMAGES FOR LATE PERFORMANCE OR FOR A FAILURE TO PERFORM. Seller reserves the right to make partial shipments and to ship products, parts or work which may be completed prior to the scheduled performance date.

C. In the event that Seller has agreed to mount motors, turbines, gears, or other products which are not manufactured by Seller and which are not an integral part of Seller's manufactured product, and a delay in the delivery of such products to Seller occurs that will cause a delay in Seller's performance date, Seller reserves the right to ship its product upon completion of manufacture and to refund an equitable portion of the amount originally included in the purchase price for mounting without incurring liability for non-performance.

D. Seller reserves to itself the right to change its specifications, drawings and standards if such changes will not impair the performance of its products, and parts, and further those products, and parts, will meet any of Buyer's specifications and other specific product requirements which are a part of this agreement. Seller is a global supplier of products and utilizes parts and products obtained worldwide, and Seller's products supplied under this contract shall be subject to Seller's sole determination as to all manufacturing, sourcing, assembly and supply unless otherwise specifically agreed in writing.

E. The manufacture and inspection of products and parts shall be to Seller's Engineering and Quality Assurance standards, plus such other inspections or tests of documentation as are specifically agreed to by Seller. Requirements for any additional inspection, tests, documentation, or Buyer witness of manufacture, test, and/or inspection shall be subject to additional charges.

4. TITLE AND RISK OF LOSS

Title and risk of loss shall pass to buyer upon delivery of products at the designated "Ex Works" as defined by Incoterms, unless otherwise wise agreed by the parties.

5. EROSION AND CORROSION

It is specifically understood that products and parts sold hereunder are not warranted for operation with erosive or corrosive fluids or for operation with any fluid or under any operating condition in variance with the specifications of this contract. No product or part shall be deemed to be defective by reason of failure to resist erosive or corrosive action of any fluid and Buyer shall have no claim whatsoever against Seller therefore. No product shall be deemed defective by reason of any effect on Seller's products of the action or results (such as vibration) of any goods or system (such as piping) not supplied by Seller.

6. BUYER'S RESPONSIBILITY

The design specifications of the equipment require the operation of the equipment within certain parameters and may call for the use of speed controls, safety devices, set points or other control devices to insure that the operation remains within design parameters. Buyer agrees and understands that the equipment must be operated and maintained within design specifications and operated within the specifications of the contract, irrespective of whether controls or devices are otherwise required.

7. WARRANTY AND LIMITATION OF LIABILITY

A. Seller warrants only that its product and parts, when shipped, will be free from defects in materials and workmanship. All claims for defective products or parts under this warranty must be made in writing immediately upon discovery and, in any event, within two (2) years of shipment by seller and all claims for defective work must be made in writing immediately upon discovery. Defective items must be held for Seller's inspection and returned to the sellers' point of original shipment upon request.

ANY UNAUTHORIZED DISSASSEMBLY, ALTERATION OF OR TAMPERING WITH ANY PRODUCT OR COMPONENT MAY "VOID" THE WARRANTY, IN THAT SUCH ACTION WILL RESULT IN SELLER BEING RELEASED AND RELIEVED FROM ITS OBLIGATIONS UNDER THIS WARRANTY AND FOR ANY FURTHER COSTS OR ACTIONS UNDER CLAUSE 7.C, FOLLOWING, AND THE BUYER ASSUMING SOLE RESPONSIBILITY FOR THE COSTS AND RESULTS OF SUCH ACTION. THE FOREGOING IS EXPRESSLY IN LIEU OF ALL OTHER WARRANTIES WHATSOEVER, EXPRESS, IMPLIED AND STATUTORY, INCLUDING WITHOUT LIMITATION, THE IMPLIED, WARRANTIES OF MERCHANTABILITY AND FITNESS.

B. ANY PRODUCT (S) SOLD HEREUNDER WHICH ARE NOT MANUFACTURED BY SELLER ARE NOT WARRANTED BY SELLER and shall be covered only by the express warranty, if any, of the manufacturer thereof. With respect to products and parts not manufactured by Seller, Seller's only obligation shall be to assign to Buyer, to the extent possible, whatever warranty Seller obtains from the manufacturer.

C. Upon Buyer's submission of a claim as provided above and its substantiation, Seller shall at its option either (i) repair or replace its product, part or work at the original place of shipment, or (ii) refund an equitable portion of the purchase price.

D. THE FOREGOING IS SELLER'S ONLY OBLIGATION AND BUYER'S EXCLUSIVE REMEDY FOR BREACH OF WARRANTY AND, EXCEPT FOR THE REMEDIES PERMITTED UNDER THE PERFORMANCE, INSPECTION AND ACCEPTANCE AND THE PATENTS CLAUSES HEREOF, THE FOREGOING IS BUYER EXCLUSIVE REMEDY AGAINST SELLER FOR ALL CLAIMS ARISING HEREUNDER OR RELATING HERETO WHETHER SUCH CLAIMS ARE BASED ON BREACH OF CONTRACT, TORT (INCLUDING NEGLIGENCE OR STRICT LIABILITY), INDEMNITY OR OTHER THEORIES. BUYER'S FAILURE TO SUBMIT A CLAIM AS PROVIDED ABOVE SHALL SPECIFICALLY WAIVE ALL CLAIMS FOR DAMAGES OR OTHER RELIEF, INCLUDING BUT NOT LIMITED TO CLAIMS BASED ON LATENT DEFECTS. IN NO EVENT SHALL BUYER BE ENTITLED TO INDIRECT, SPECIAL, INCIDENTAL OR CONSEQUENTIAL DAMAGES, NOR FOR DAMAGES FOR LOSS OF USE, LOST PROFITS OR REVENUE, INTEREST, LOST GOODWILL, WORK OR PRODUCTION STOPPAGE, IMPAIRMENT OF OTHER GOODS, INCREASED EXPENSES OF OPERATION, OR THE COST OF PURCHASING REPLACEMENT POWER OR OTHER SERVICES BECAUSE OF SERVICE INTERRUPTIONS. FURTHERMORE, IN NO EVENT SHALL SELLER'S TOTAL LIABILITY FOR DAMAGES OF BUYER EXCEED THE PURCHASE PRICE OF THE PRODUCTS OR PARTS MANUFACTURED BY SELLER AND UPON WHICH SUCH LIABILITY IS BASED. ANY ACTION ARISING HEREUNDER RELATED HERETO, WHETHER BASED ON BREACH OF CONTRACT, TORT (INCLUDING NEGLIGENCE) OR OTHER THEORIES, MUST BE COMMENCED WITHIN ONE (1) YEAR AFTER THE CAUSE OF ACTION ACCRUES OR IT SHALL BE BARRED.

8. PURCHASER'S REPRESENTATIONS & WARRANTIES

Purchaser represents and warrants that the products(s) covered by this contract shall not be used in or in connection with a nuclear facility or application. The parties agree that this representation and warranty is material and is being relied on by seller. This provision may be modified in a separate writing signed by an officer of Price Pump Co.

9. PATENTS

Seller agrees to assume the defense of any suit for infringement of any patents brought against Buyer to the extent of such suit charges infringement of an apparatus or product claim by Seller's product in and of itself, provided (i) said product is built entirely to Seller's design, (ii) Buyer notifies Seller in writing of the filing of such suit within ten (10) days after the service of process thereof, and (iii) Seller is given complete control of the defense of such suit, including the right to defend, settle and make changes in the product for the purpose of avoiding infringement of any process or method claims. Provided however, Seller will not defend any suit for infringement of a claimed patent where such alleged infringement is the result of following specific instruction furnished by Seller.

10. EXTENT OF SUPPLY

Only products as listed in Seller's proposal are included in this agreement. It must not be assumed that Seller has included anything beyond same.

11. MANUFACTURING SOURCES

To maintain delivery schedules, Seller reserves the right to have all or any part of the Buyer's order manufactured at any of Sellers', sellers' licensees or sub contractors' plants, globally.

12. TERMS OF PAYMENT

Net 30 days from date of invoice.

13. ARBITRATION

In the event a dispute arises between the parties relating to or arising out of this agreement, the parties agree to attempt to have their senior management amicably settle the matter. In the event that the matter cannot be settled, the parties shall submit all disputes relating to this Agreement (whether contract, tort, products liability or otherwise) to binding Arbitration before a panel of arbitrators under the Commercial Dispute Resolution Procedures of the American Arbitration Association. Each party shall appoint an arbitrator and the third shall be selected in accordance with the rules of the American Arbitration Association. Judgment upon the award may be entered in any court having jurisdiction. The parties shall cooperate in providing reasonable disclosure of relevant documents. Each party shall bear its own expenses, and the costs and fees of the arbitration shall be borne as allocated by the Arbitrator.