



# MS50 SS Parts List

**PRICE PUMP CO.**

MS50 plist.doc rev. B

Key #	Description	Qty.	Number of Stages					6MS
			1MS	2MS	3MS	4MS	5MS	
A.	Suction Plate		3010	3010	3010	3010	3010	3010
B.	Impeller(s)	(1 req'd. per stage)	3040-4.12	3040-4.12	3040-4.12	3040-4.12	3040-4.12	3040-4.12
	Setscrews	(2 req'd. per stage)	3080	3080	3080	3080	3080	3080
C.	O Rings (Diffuser/Volute)							
	Fluorocarbon	(1 + # of stages req'd.)	3070	3070	3070	3070	3070	3070
	PTFE	(1 + # of stages req'd.)	3071	3071	3071	3071	3071	3071
	Neoprene	(1 + # of stages req'd.)	3072	3072	3072	3072	3072	3072
	EPR	(1 + # of stages req'd.)	3073	3073	3073	3073	3073	3073
D.	Diffuser	(1 - # of stages req'd.)	N/A	3020-1	3020-1	3020-1	3020-1	3020-1
E.	Bushing(s):							
	Graphite	(1 - # of stages req'd.)	N/A	3075	3075	3075	3075	3075
	GFT	(1 - # of stages req'd.)	N/A	3076	3076	3076	3076	3076
F.	Volute		3000	3000	3000	3000	3000	3000

Price® Pump Co.



# MS50 SS Parts List

**PRICE PUMP CO.**

MS50 plist.doc rev. B

Key #	Description	Qty.	Number of Stages					
			1MS	2MS	3MS	4MS	5MS	6MS
G.	Volute Bolts	(8 req'd.)	0917	0917	0917	0917	0917	0917
J.	Shaft w/setscrews:							
	5/8" ID		3050-1	3055-1	3060-1	3065-1	3066-1	3067-1
	7/8" ID		3132-1	3133-1	3134-1	3135-1	3136-1	3137-1
K.	Slinger, 7/8"		0522	0522	0522	0522	0522	0522
L.	Motor Bolts	(2 of ea. req'd.)	0673 / 0593	0673 / 0593	0673 / 0593	0673 / 0593	0673 / 0593	0673 / 0593
M1.	Motor		Specify P/N					
M2.	Power Frame 5/8" ID Shaft		5478	5478	5478	5478	5478	5478
	Power Frame 7/8" ID Shaft		5501	5501	5501	5501	5501	5501
M3.	Air Motor		Specify P/N					
N.	Stage Bolts	(4 req'd.)	3083	3084	3085	3086	3087	3088
P.	Stage Nuts	(4 req'd.)	3082	3082	3082	3082	3082	3082
Q.	Washers	(4 req'd.)	3081	3081	3081	3081	3081	3081
R.	Base		0199	0199	0199	0199	0199	0199

Price® Pump Co.

21775 Eighth Street East \* Sonoma, CA 95476-0329 \* (707) 938-8441 \* Fax (707) 938-0764



# MS50 SS Parts List

**PRICE PUMP CO.**

MS50 plist.doc rev. B

Key #	Description	Qty.	Number of Stages					
			1MS	2MS	3MS	4MS	5MS	6MS
S.	Bracket		0972	0972	0972	0972	0972	0972
T.	Stage separator(s):							
	Single Seal (1 - # of stages req'd.)	N/A	3030	3030	3030	3030	3030	3030
	Double Seal	N/A	3030-1(1 req'd.)	3030(1 req'd.)	3030(2 req'd.)	3030(3 req'd.)	3030(4 req'd.)	
				3030-(1 req'd.)	3030-1(1 req'd.)	3030-1(1 req'd.)	3030-1(1 req'd.)	3030-1(1 req'd.)
	Suction Plate for Dbl Seal		3010-1	N/A	N/A	N/A	N/A	N/A
	Seal w/Seat:							
U1.	T.21 Fluorocarbon Single Seal		0553	0553	0553	0553	0553	0553
U2.	T.21 Fluorocarbon Dbl Seal (2 req'd.)		0985	0985	0985	0985	0985	0985
U3.	T.9 PTFE Single Seal		1150	1150	1150	1150	1150	1150
W.	Double Seal Cover		0973	0973	0973	0973	0973	0973
V.	Seal Cover Gasket		0974	0974	0974	0974	0974	0974
X.	Seal Cover Bolts (3 req'd.)		0256	0256	0256	0256	0256	0256
Y.	Quench Lip Seal Fluorocarbon		0891	0891	0891	0891	0891	0891

Price® Pump Co.

21775 Eighth Street East \* Sonoma, CA 95476-0329 \* (707) 938-8441 \* Fax (707) 938-0764



**PRICE PUMP CO.**

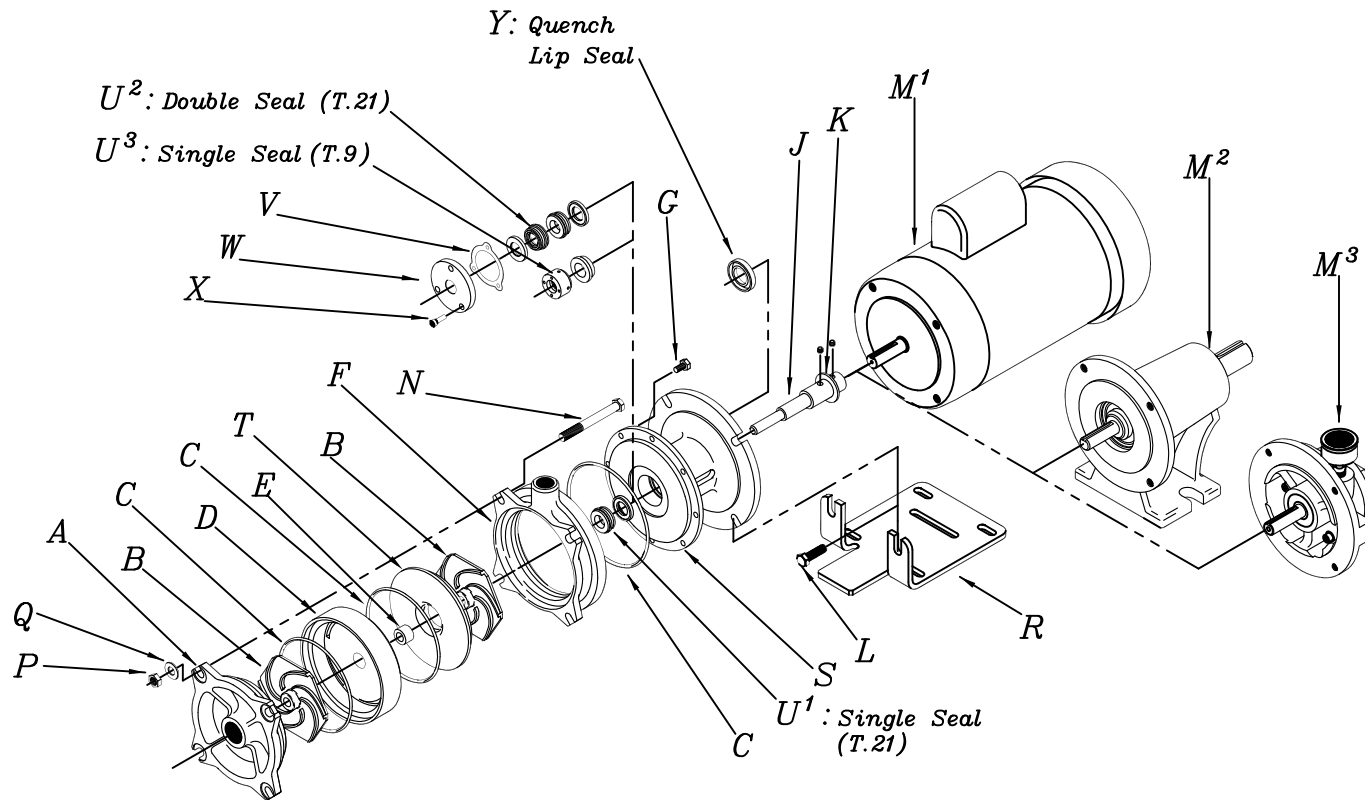

MS50

Price® Pump Co.

21775 Eighth Street East \* Sonoma, CA 95476-0329 \* (707) 938-8441 \* Fax (707) 938-0764