



Air Operated Diaphragm Pump



Max Flow:

115 GPM with 105 psi air supply

FEATURES

- **Stall-Free Design** – A patented non-centering, spring assisted shifter is incorporated into every “Y” series pump, ensuring a positive shift every time. All “Y” series pumps eliminate the need of pre-packing or extended lubrication.
- **Oil-less Operation** – Oil-less operation “Y” series pumps incorporate no metal-to-metal wearing surfaces. This design means no oil misting into the environment that would create an unhealthy working condition, and no oil, lubricants or grease to contaminate your products. Our oil-less design results in lower operating and maintenance costs.
- **Quiet Operation** – Air valve design minimizes exhaust noise providing a significantly quieter work environment.
- **Portable/Simple Installation** – Simply connect your air supply line and liquid lines; the pump is now ready to perform. There are no complex controls to install and operate.
- **Submersible** – If external components are compatible, these pumps can be submerged in the liquid by simply running the exhaust line above the liquid level.

AOD1.5 - *(-P, -K)

*Pump Body Materials

- P – Polypropylene †
- K – Kynar® (PVDF)

Elastomers

- Buna-N
- Neoprene
- Nordel®
- Santoprene®
- Teflon®
- Viton®

Applications

- Aircraft Industry
- Automotive
- Beverage Industry
- Chemical and Petroleum
- Glass and Fiberglass
- Marine
- Metal and Steel
- Mine and Construction
- Paint
- Paper and Wood

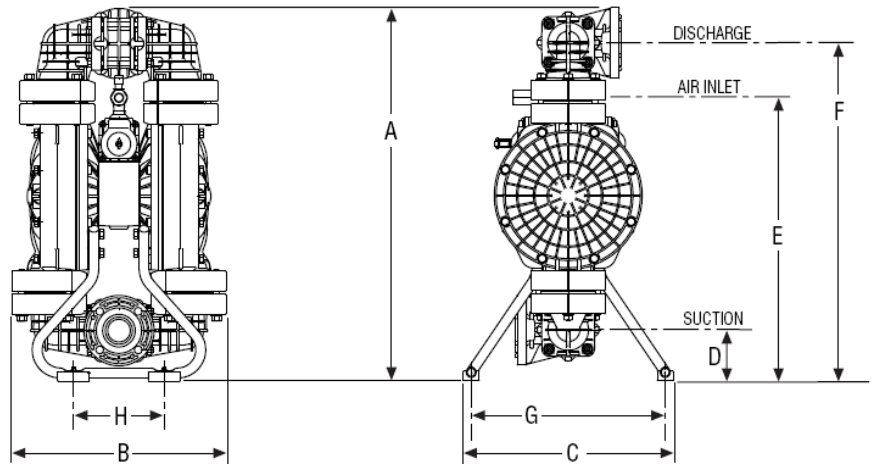

MODEL (Dimensions)		Polypro, Kynar®
		AOD1.5-xxxx-Y
SUCTION (Bottom)	Inches	1 1/2 ANSI Flange*
DISCHARGE (Top)	Inches	1 1/2 ANSI Flange*
A – Total Height	Inches (mm)	29.50 (750)
B – Total Depth	Inches (mm)	15.75 (400)
C – Total Width	Inches (mm)	12.20 (310)
Air Inlet Size		1/2" FNPT
Air Exhaust Size		3/4" FNPT
D – Suction Dimension	Inches (mm)	4.4 (112)
E – Air Inlet Dimension	Inches (mm)	23.46 (596)
F – Discharge Dimension	Inches (mm)	26.9 (682)
G – Mounting Dimension	Inches (mm)	10.83 (275)
H – Mounting Dimension	Inches (mm)	7.83 (200)
NOTE: Pump dimensions may vary depending on configuration. Dimensions are to be used for reference only.		
*ANSI FLANGE B16.5 #150		



AOD® is a registered trademark of Price® Pump Co.; Teflon® is a registered trademark of DuPont; Viton® and Nordel® are registered trademarks of DuPont Dow Elastomers; Santoprene® is a registered trademark of Monsanto Company.
 † Material is not ATEX certified.

AOD1.5 -P, -K

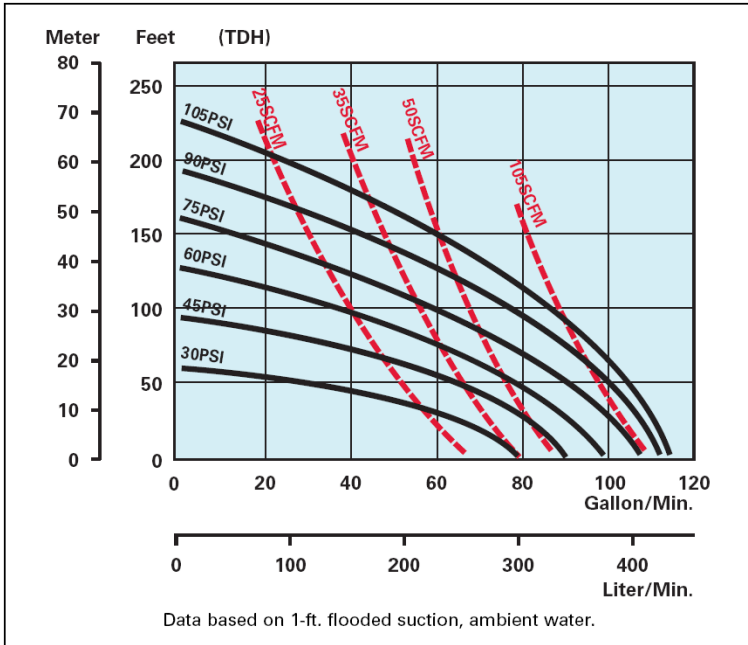

The performance curves shown and other published literature reflect an average performance for all materials and all elastomers, including Teflon®. Derating of the performance is not necessary for Teflon® fitted pumps.

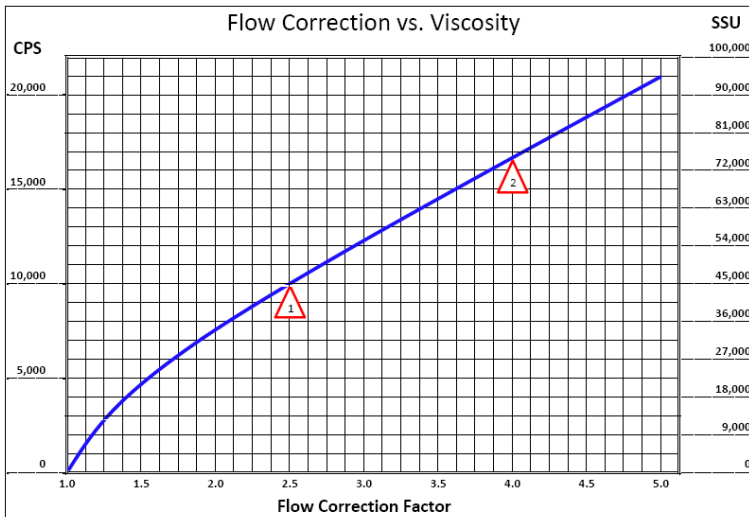

To determine the correction flow rate, find the intersection of the VISCOSITY on the above curve and read the FLOW CORRECTION FACTOR. Multiply this factor by the desired flow of the pump and use this new flow rate to select a pump from the performance curves.

Example Δ 10,000 CPS = 2.5 Flow Correction Factor.
If viscous flow desired is 42 GPM, then multiply 42 by 2.5 = 105 (GPM equivalent water flow)

Example Δ 74,000 SSU = 4.0 Flow Correction Factor.
If viscous flow desired is 35 GPM, then multiply 35 by 4.0 = 140 (GPM equivalent water flow)



21775 Eighth Street East,
Sonoma, CA 95476-0329
MAIN (707) 938-8441
TOLL FREE (800) 345-PUMP (7867)
FAX (707) 938-0764
www.pricepump.com
E-mail: sales@pricepump.com

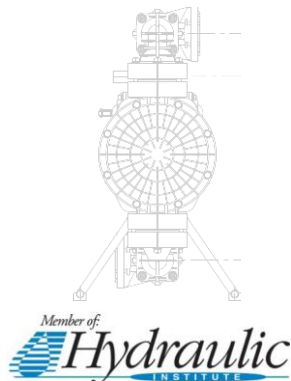

Technical Data		
Maximum flow	GPM (liters per Minute)	115 (435)
Displacement/Stroke		
Elastomer Diaphragms	Gal (liters)	0.79 (3.0)
Teflon® Diaphragms		0.37 (1.4)
Max Air Inlet Pressure	PSI (bar)	100 (6.9)
Max Spherical Solids Size	IN (mm)	9/32 (7.2)
High Temperature Limit	*(See elastomer specs. below)	
Low Temperature Limit	°F (°C)	40 (4.44)
Shipping Weight	Lbs (kg)	
Polypropylene		74.8 (33.9)
Kynar® (PVDF)		74.8 (33.9)

*Elastomer Kits				
Maximum Liquid Temperature				
MATERIAL	Polypro	P/N	Kynar®	P/N
Buna-N	180°F (82°C)	K40-PN	Not Available	
Neoprene	180°F (82°C)	K40-PC	Not Available	
Nordel®	180°F (82°C)	K40-PE	Not Available	
Santoprene®	180°F (82°C)	K40-PS	212°F (100°C)	K40-VS
Teflon®	180°F (82°C)	K40-PT	212°F (100°C)	K40-VT
Viton®	180°F (82°C)	K40-PV	Not Available	

Materials of Construction	
Air Valve Housing	Aluminum
Air Chambers	Aluminum
Spool Housing	Aluminum
Pump External Finish	Natural (Not Painted)
Valve Type	Elastomeric Ball

Suction Lift	
Elastomer Type (Material)	Dry Prime
Standard (Polypro, Kynar®)	18 Feet (5.48 meters)

Your Local Price® Pump Distributor: